

tekeningenlijst verkooptekeningen fase 1 BEEMD					
tekening	Sheet Name	Bouwnummers	Project Phase	datum	tekening_status
VK-019-1	Plattegronden	19 & 28	VK fase 1	-	voorlopig
VK-019-2	Gevelaanzichten en doorsneden	19 & 28	VK fase 1	-	voorlopig
VK-020-1	Plattegronden	20 & 23	VK fase 1	-	voorlopig
VK-020-2	Gevelaanzichten en doorsneden	20 & 23	VK fase 1	-	voorlopig
VK-020-3	Kopersopties	19 t/m 33, 70 t/m 80	VK fase 1 / 3b / 4	-	voorlopig
VK-020-4	Kopersopties uitbouw	19 t/m 25, 28 t/m 33	VK fase 1 / 3b / 4	-	voorlopig
VK-021-1	Plattegronden	21, 22, 24 & 29 t/m 32	VK fase 1	-	voorlopig
VK-021-2	Gevelaanzichten en doorsneden	21, 22, 24 & 29 t/m 32	VK fase 1	-	voorlopig
VK-025-1	Plattegronden	25 & 33	VK fase 1	-	voorlopig
VK-025-2	Gevelaanzichten en doorsneden	25 & 33	VK fase 1	-	voorlopig
VK-070-1	Plattegronden	70	VK fase 1	-	voorlopig
VK-070-2	Gevelaanzichten en doorsneden	70	VK fase 1	-	voorlopig
VK-071-1	Plattegronden	71, 73, 76, 78 & 79	VK fase 1	-	voorlopig
VK-071-2	Gevelaanzichten en doorsneden	71, 73, 76, 78 & 79	VK fase 1	-	voorlopig
VK-071-3	Kopersoptie uitbouw	70 t/m 80	VK fase 1 / 3b / 4	-	voorlopig
VK-072-1	Plattegronden	72 & 77	VK fase 1	-	voorlopig
VK-072-2	Gevelaanzichten en doorsneden	72 & 77	VK fase 1	-	voorlopig
VK-074-1	Plattegronden	74 & 80	VK fase 1	-	voorlopig
VK-074-2	Gevelaanzichten en doorsneden	74 & 80	VK fase 1	-	voorlopig
VK-075-1	Plattegronden	75	VK fase 1	-	voorlopig
VK-075-2	Gevelaanzichten en doorsneden	75	VK fase 1	-	voorlopig
VK-R	Renvooi	Alle bouwnummers	VK fase 1/3a/3b/4	-	voorlopig

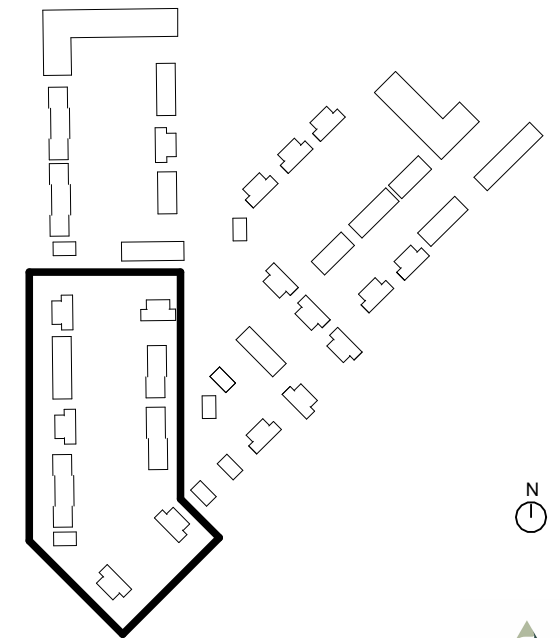

Omschrijving  
tekeningenlijst

voorlopig

Onderdeel  
Verkooptekening

tekeningnummer  
VK-001-5.40

Bouwnummer(s)  
19 t/m 33, 70 t/m 80

getekend  
13-09-2024

schaal  
formaat  
A3

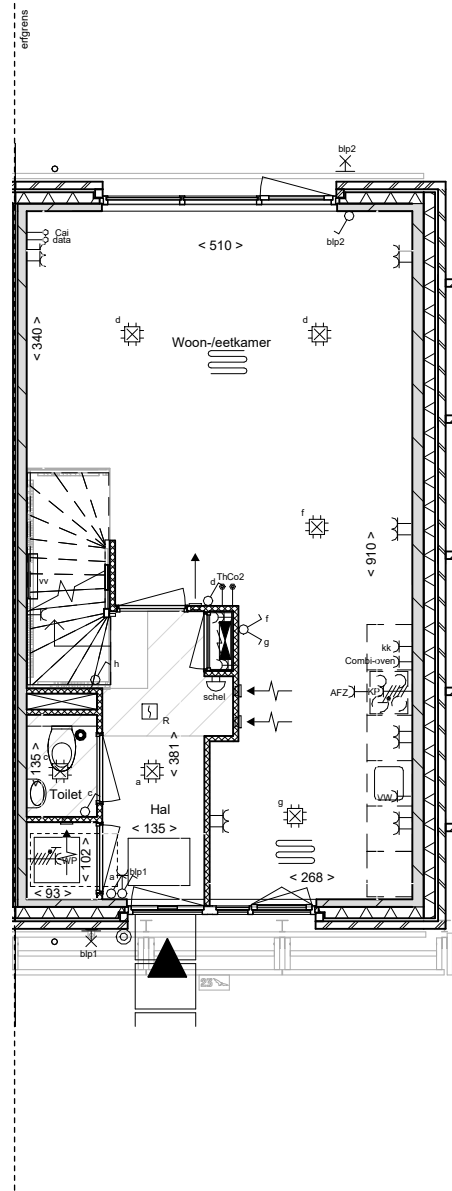

begane grond

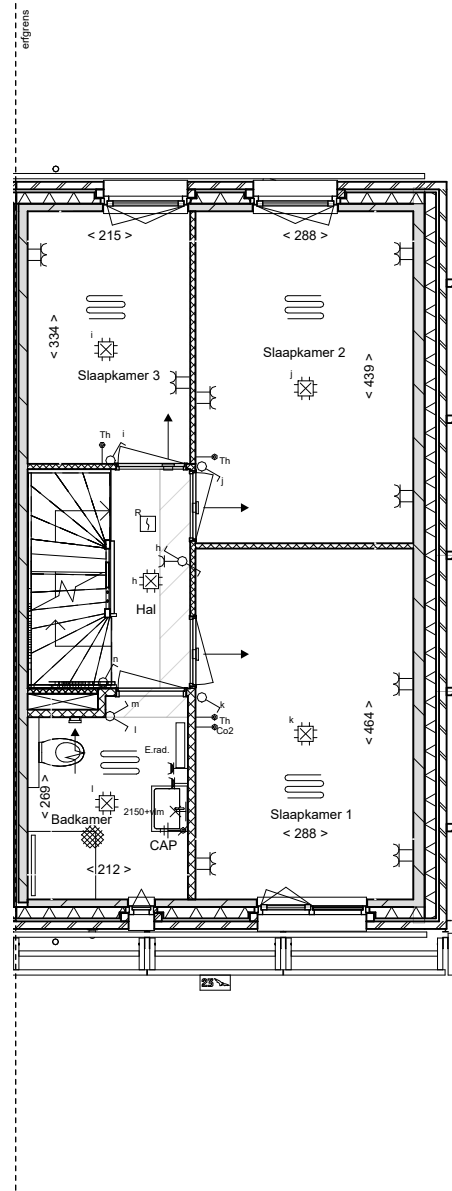

eerste verdieping

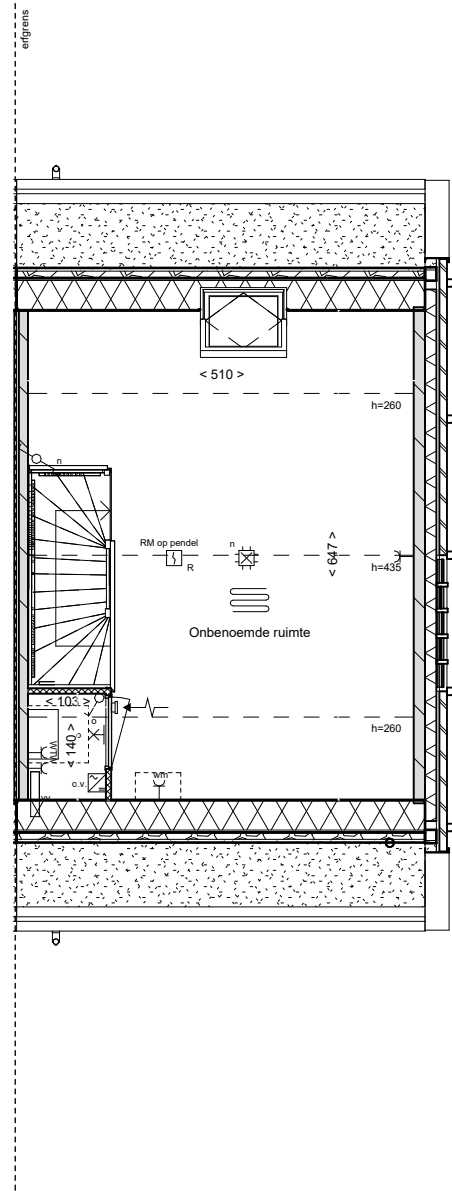

zolder

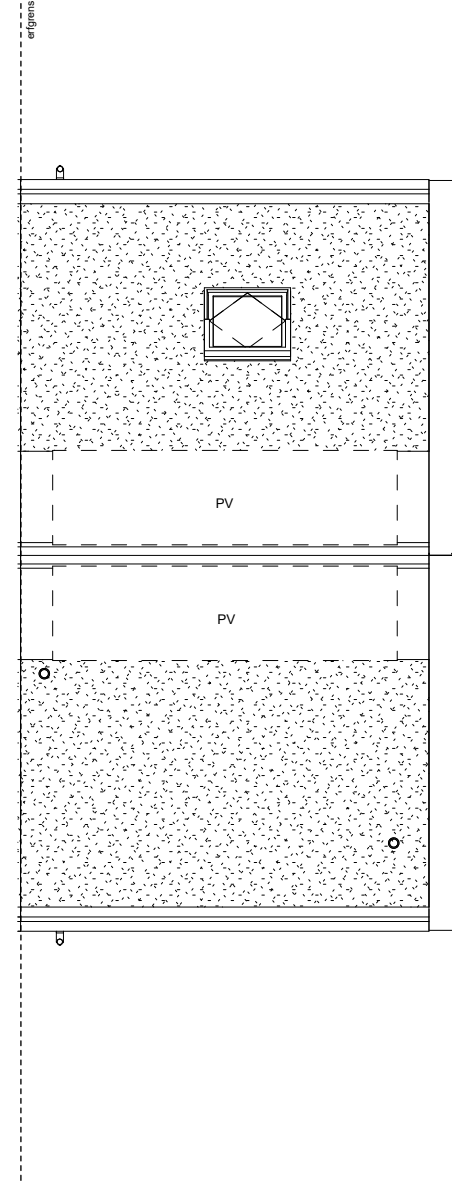

dakaanzicht

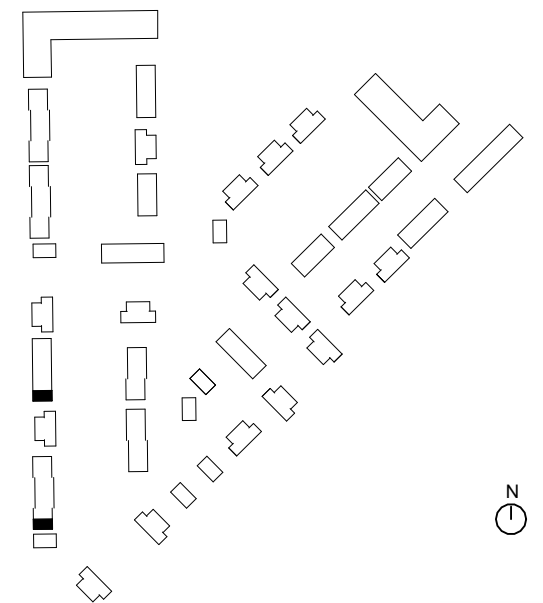

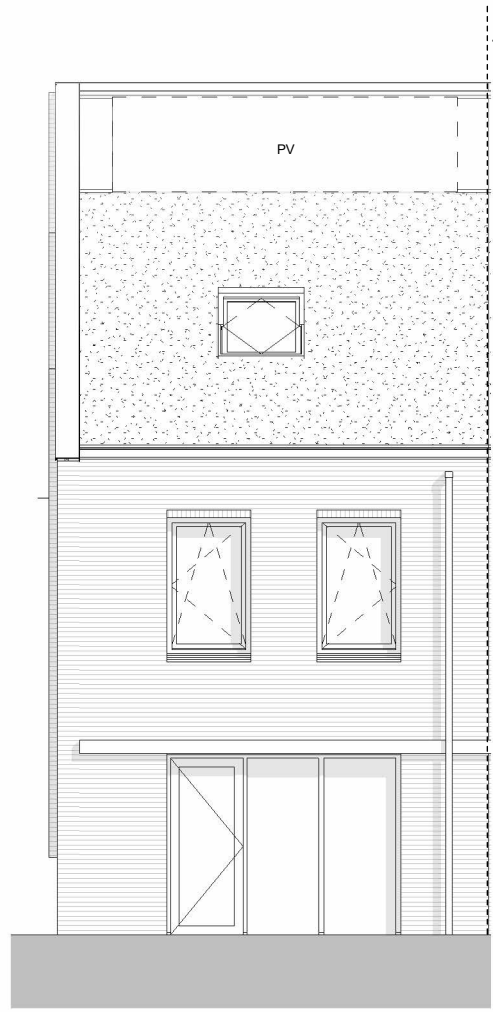

achtergevel

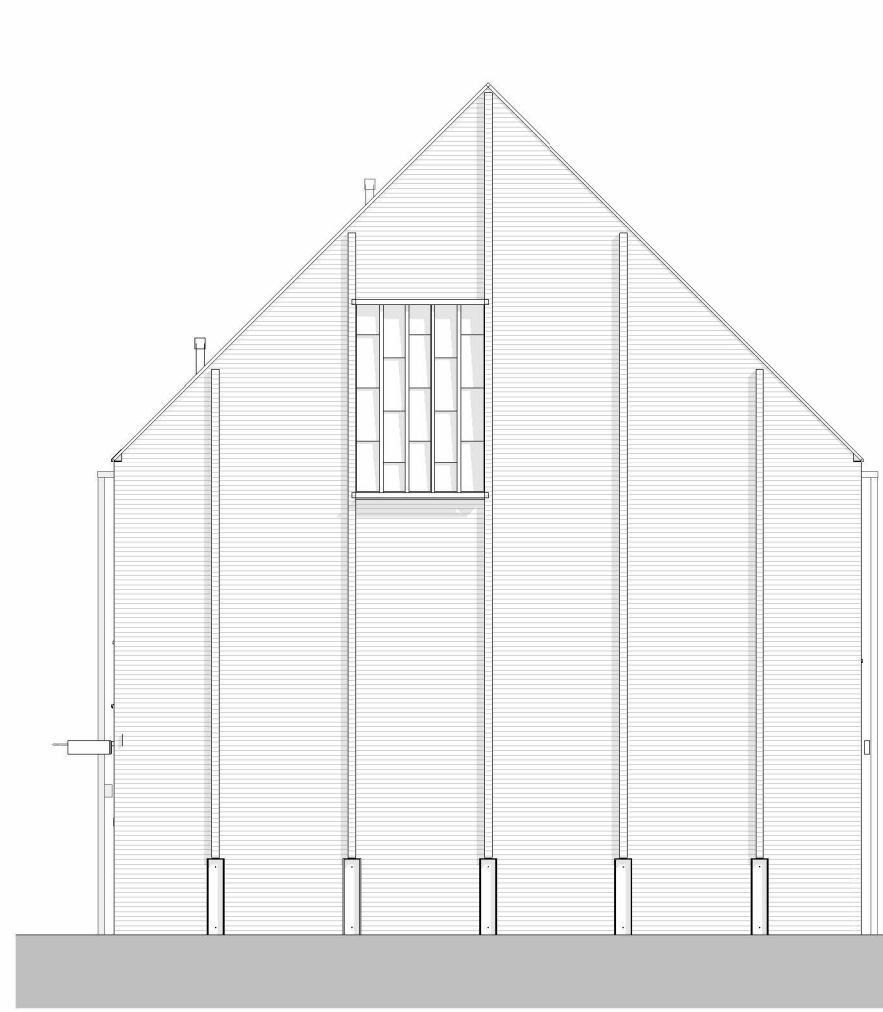

kopgevel met vloermuiskasten

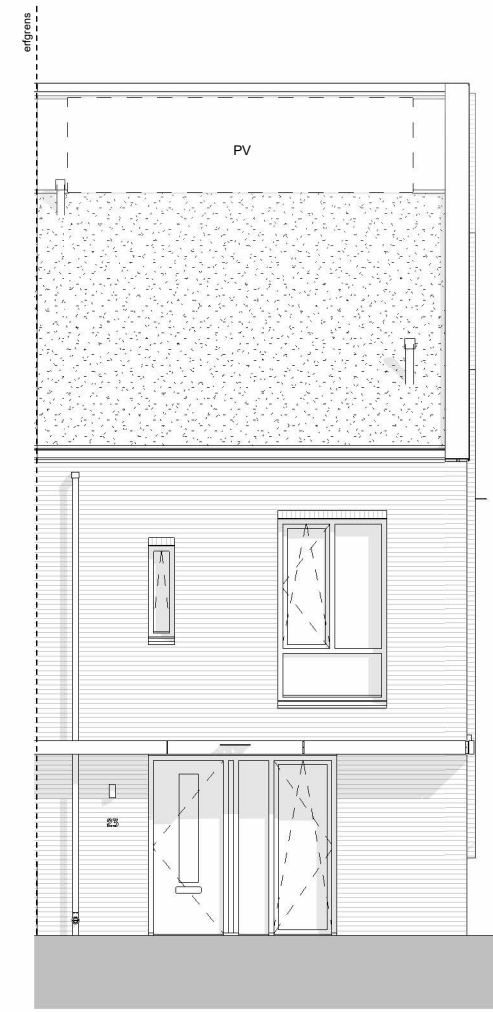

voorgevel

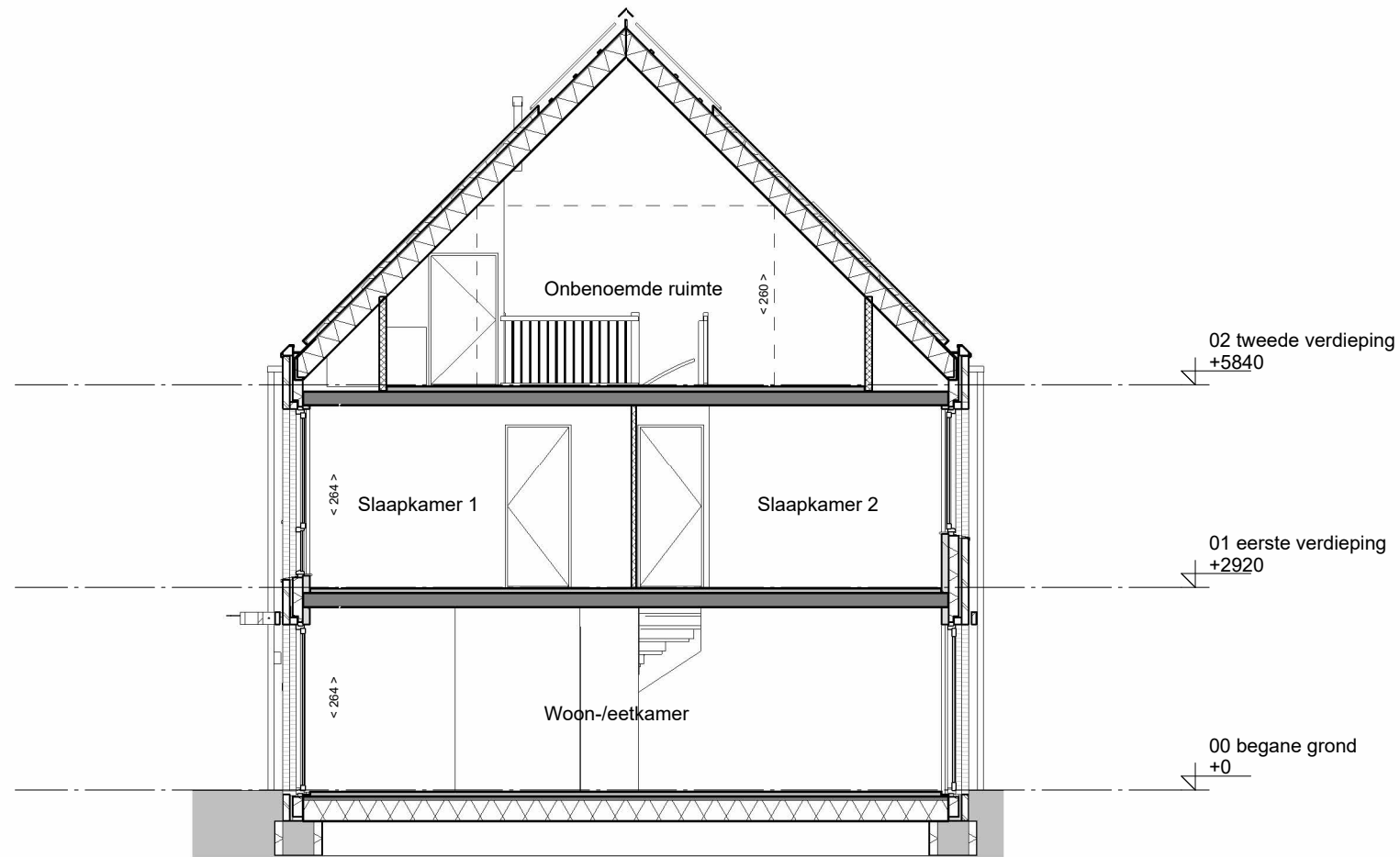

doorsnede

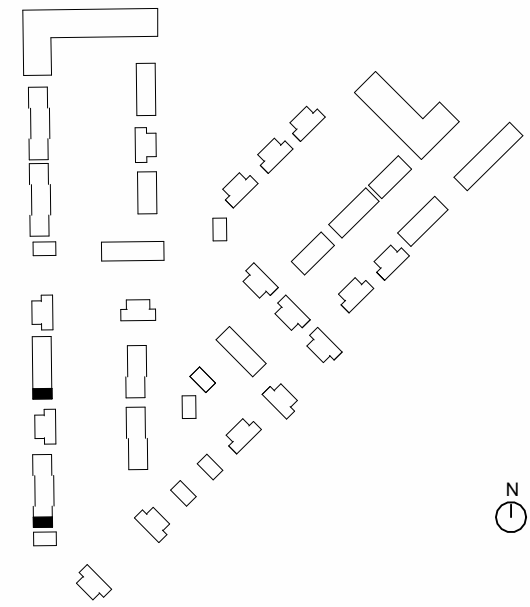

Omschrijving			
<b>Gevelaanzichten en doorsneden voorlopig</b>			
Onderdeel	tekeningnummer		
Verkooptekening	<b>VK-019-2</b>		
Bouwnummer(s)	getekend	schaal	formaat
19 & 28	-	1 : 100	A3

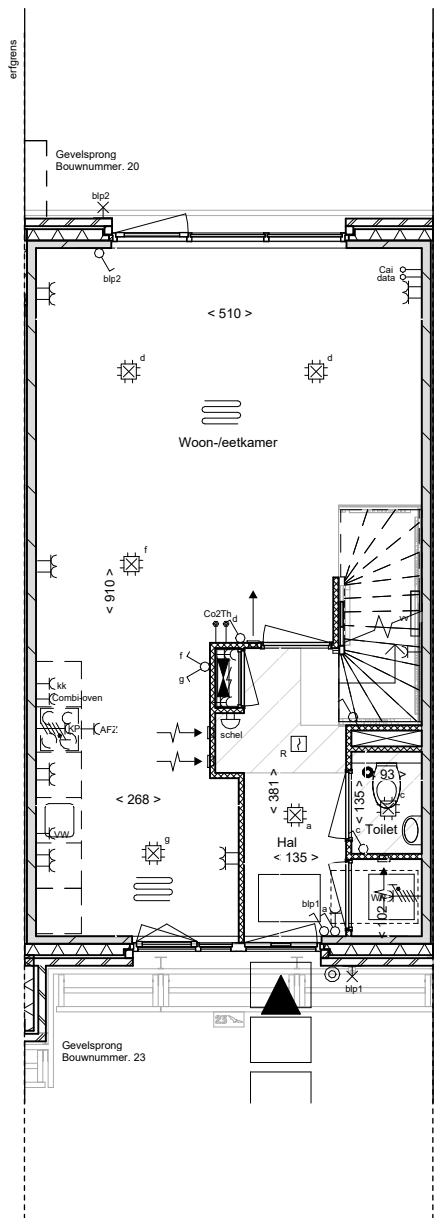

begane grond

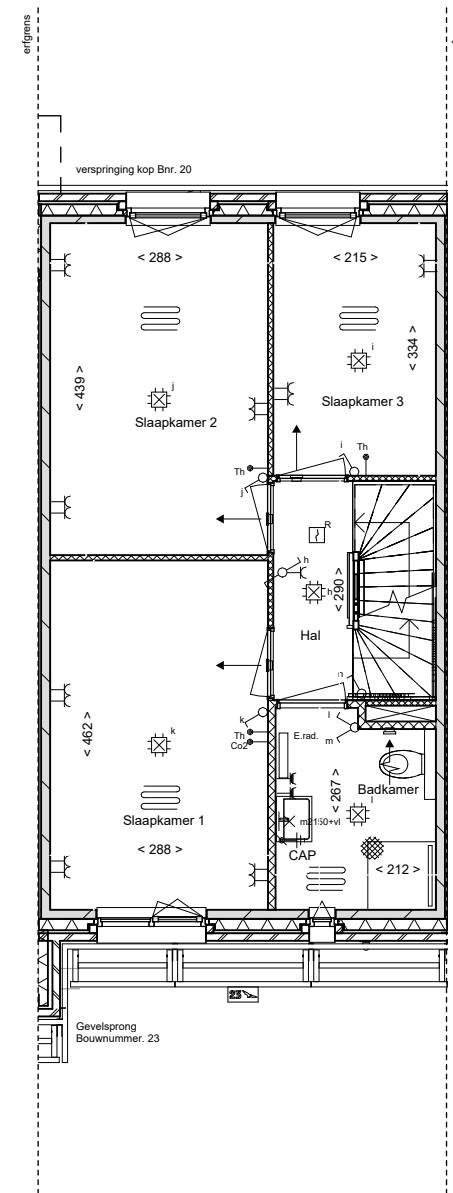

eerste verdieping

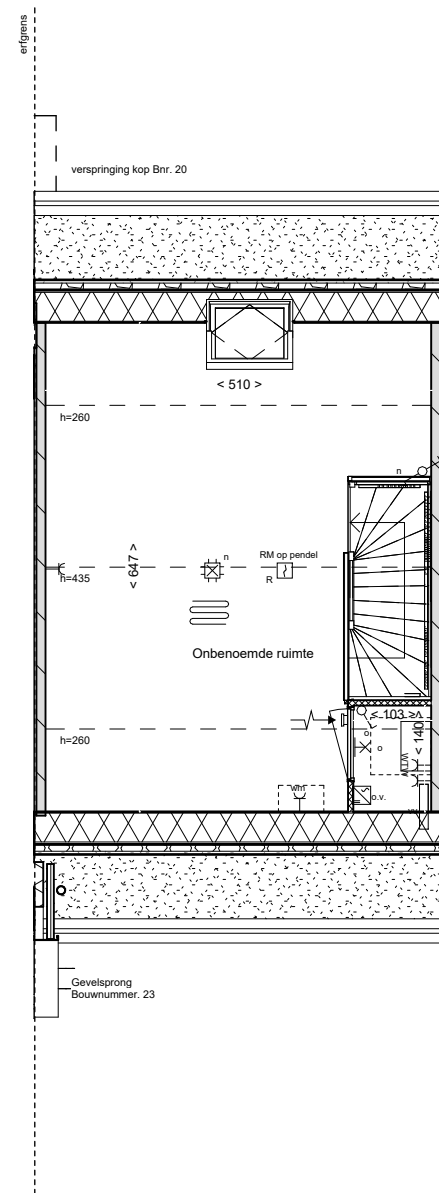

zolder

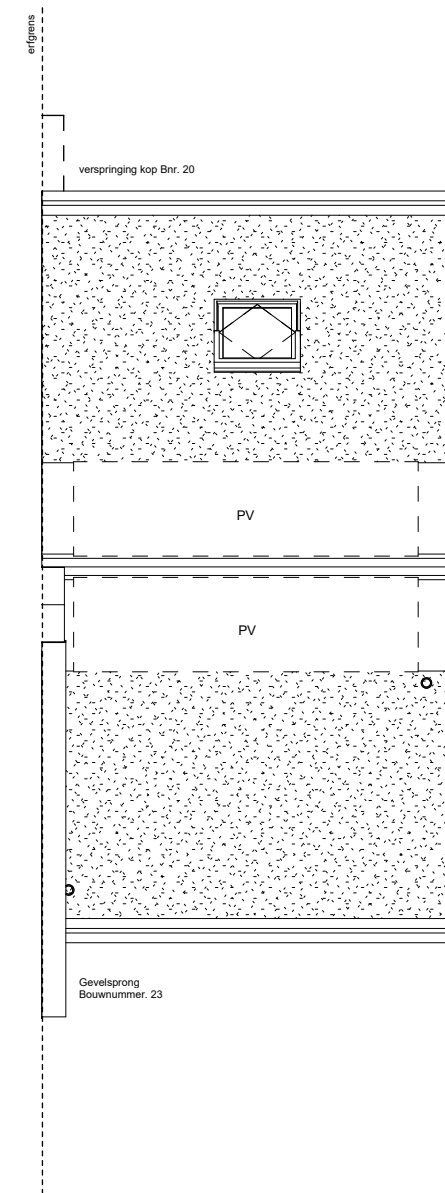

dakaanzicht

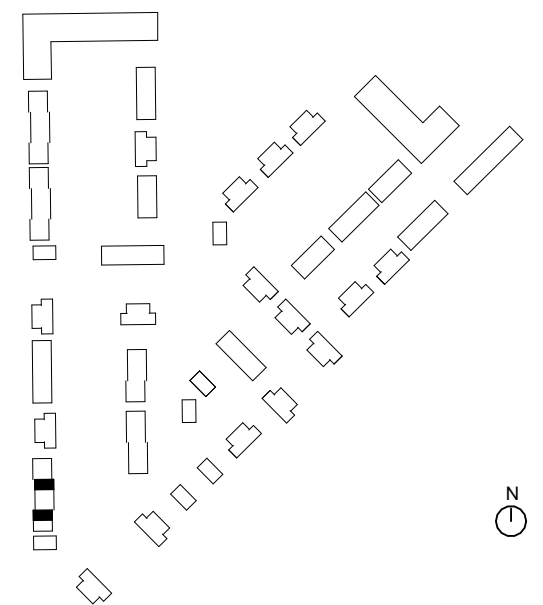

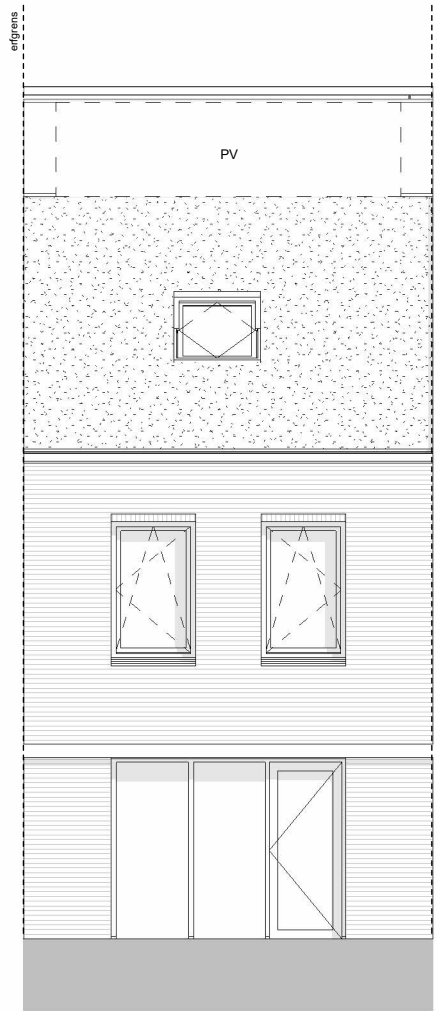

achtergevel

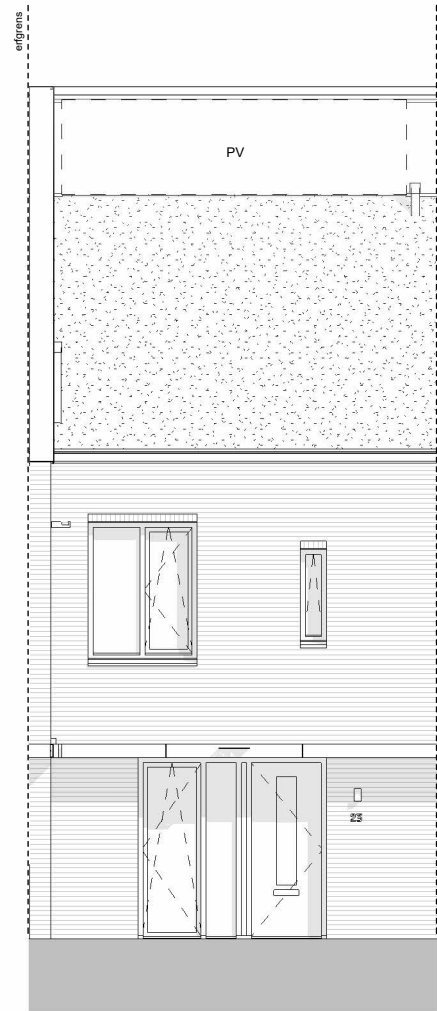

voorgevel

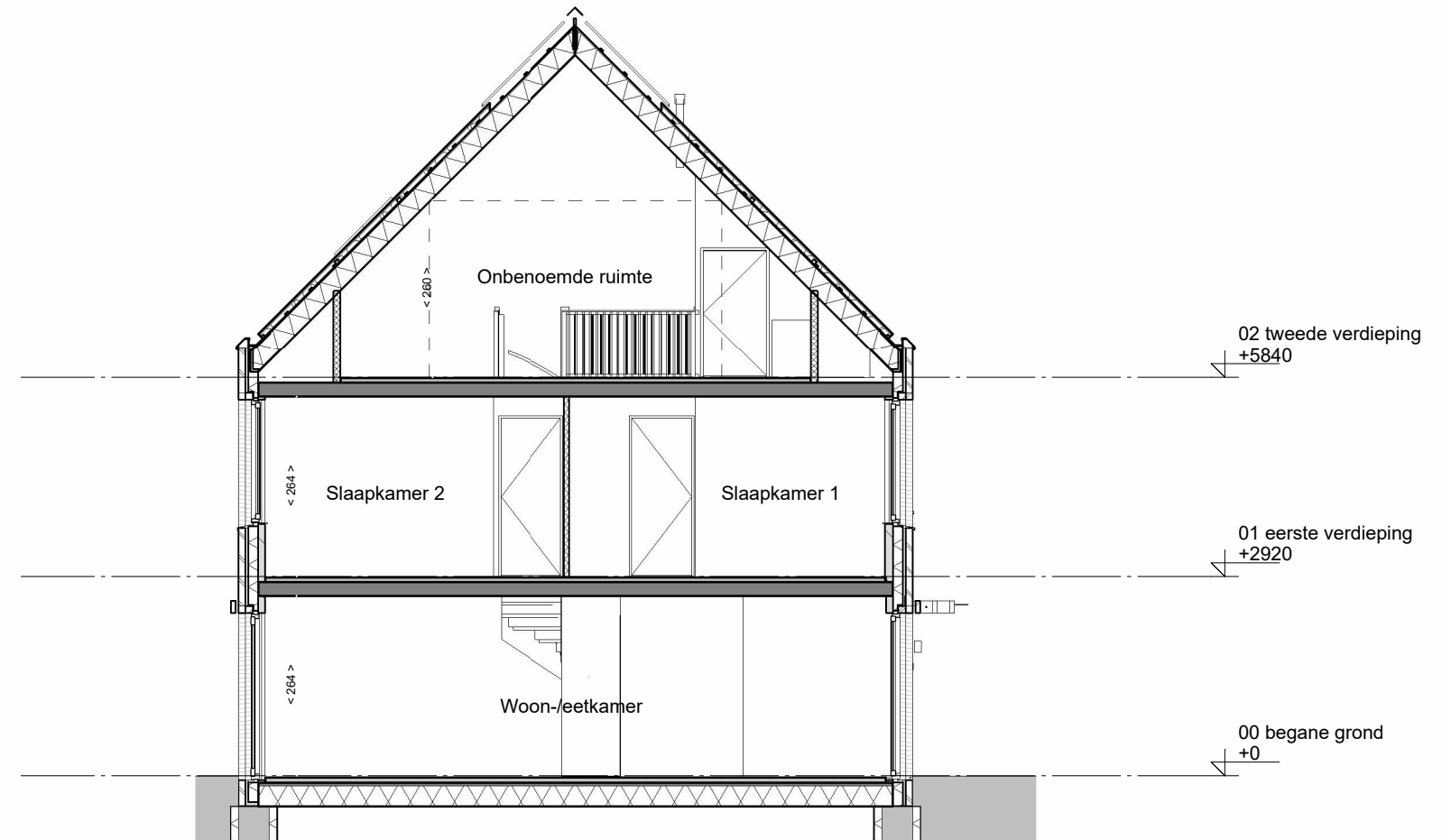

doorsnede

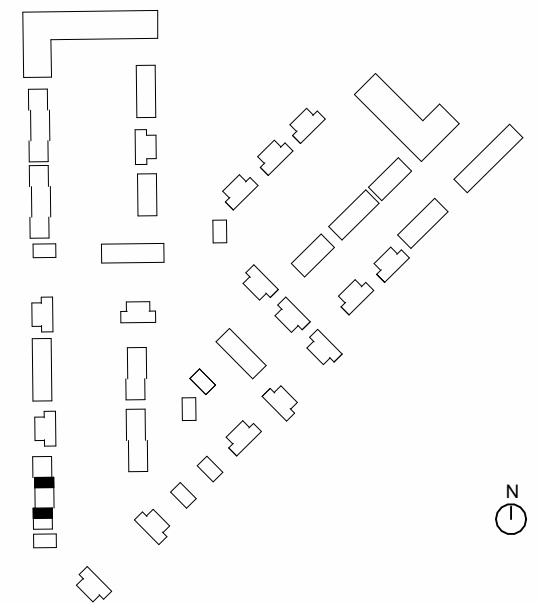

Omschrijving  
**Gevelaanzichten en doorsneden voorlopig**

Onderdeel	tekeningnummer		
Verkooptekening	VK-020-2		
Bouwnummer(s)	getekend	schaal	formaat
20 & 23	-	1 : 100	A3

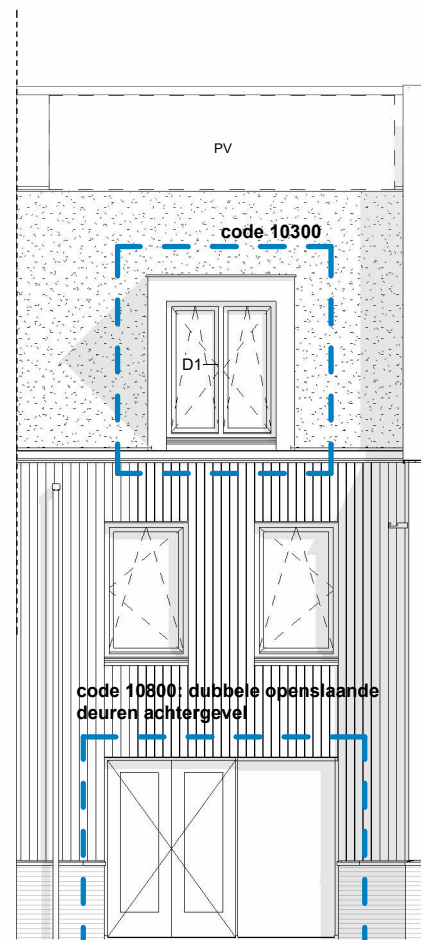

achtergevel

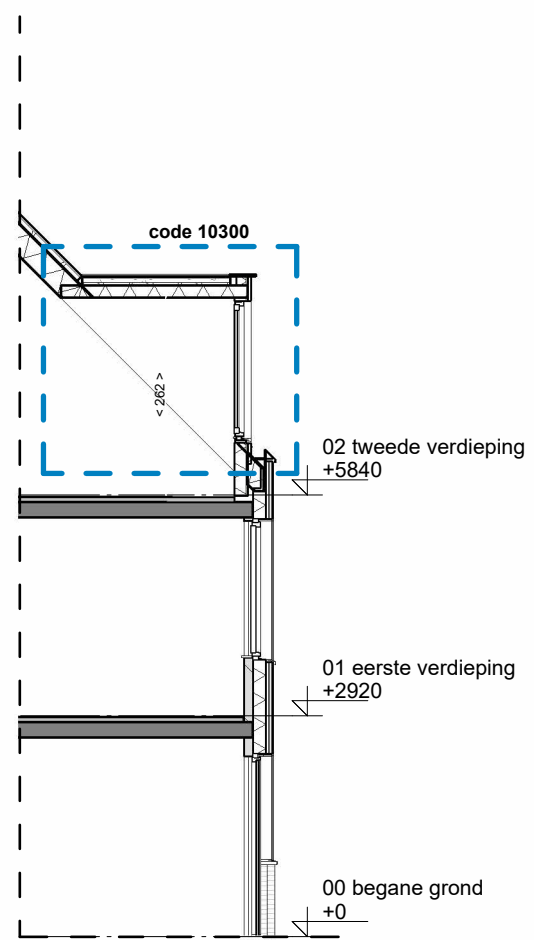

doorsnede

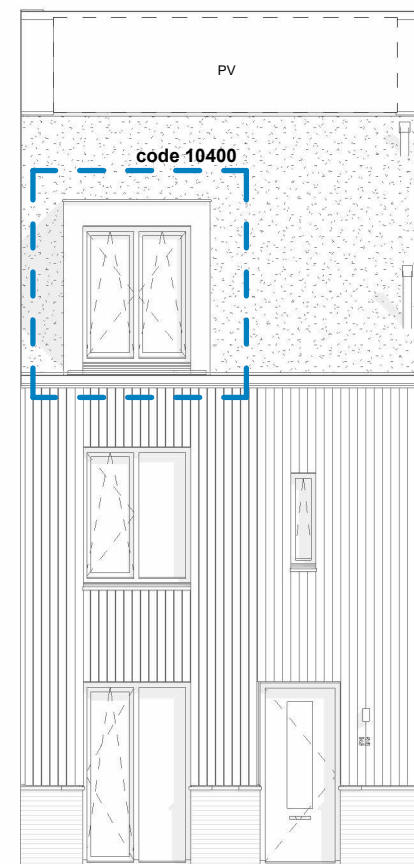

voorgevel

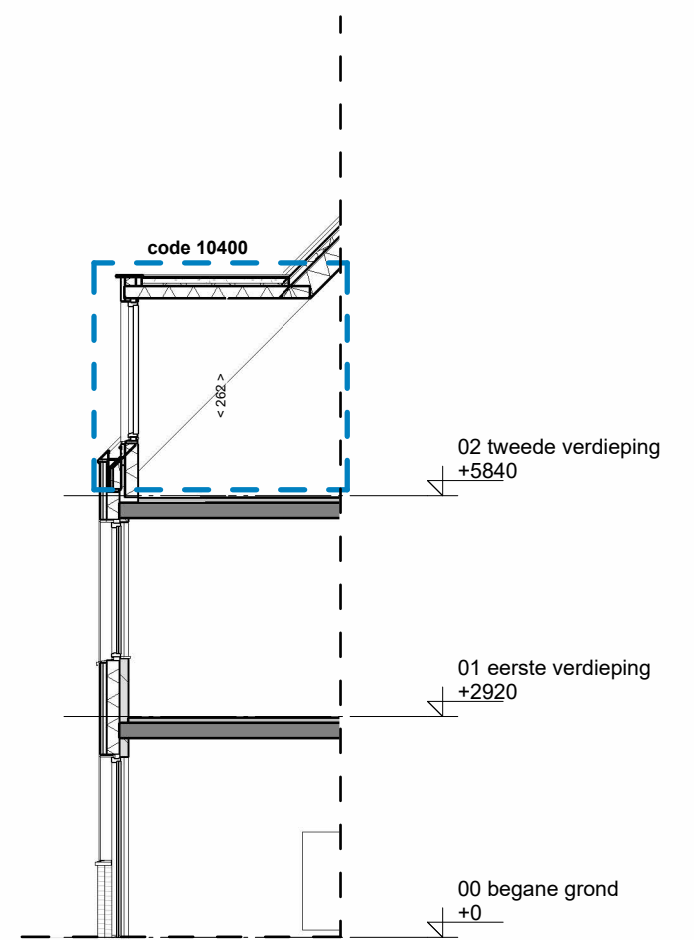

doorsnede

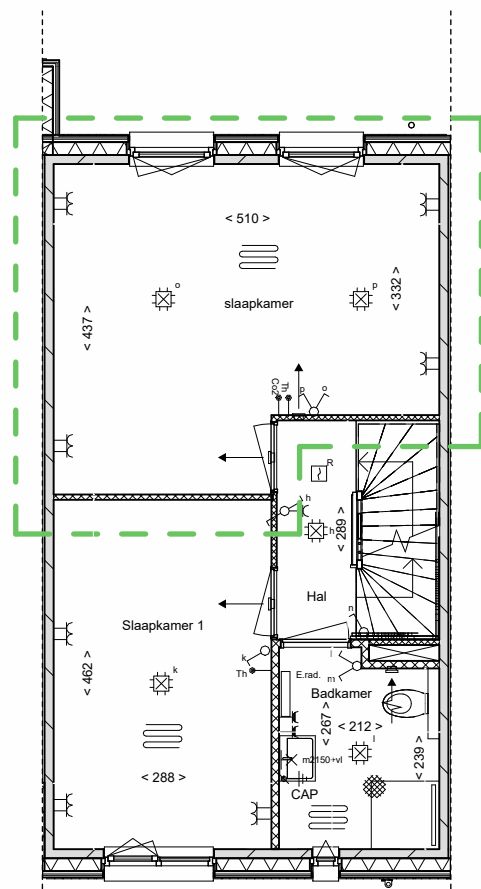

eerste verdieping

code 12100: slaapkamers samenvoegen

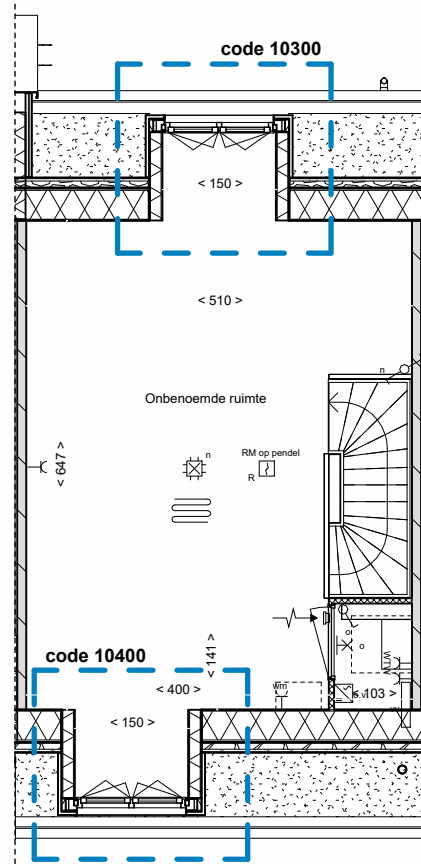

tweede verdieping

code 10300: dakkapel achtergevel  
code 10400: dakkapel voorgevel

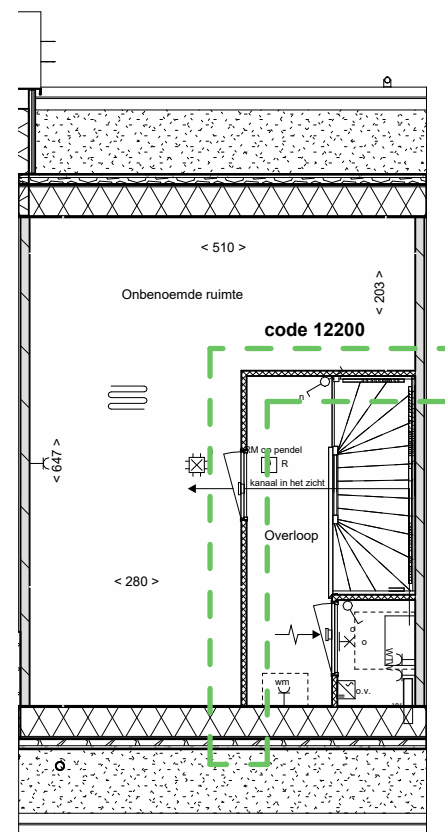

tweede verdieping

code 12200: zolderindeling

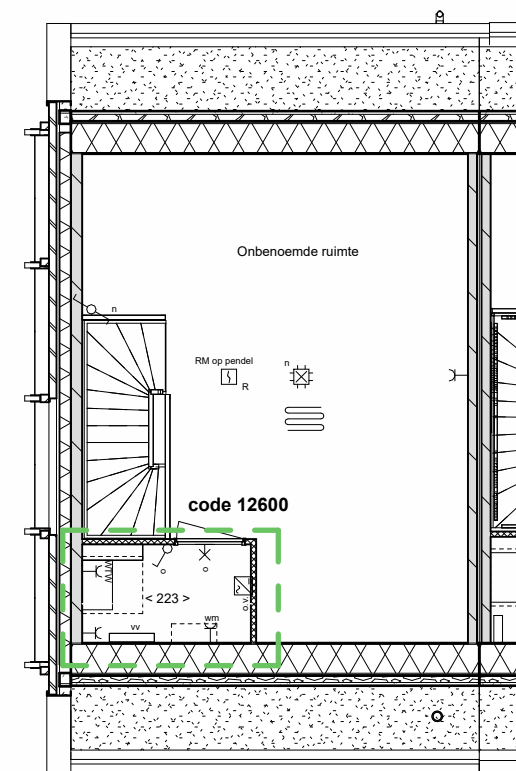

tweede verdieping

code 12600: grote technische ruimte

**NB:**  
Kopersopties slechts ter indicatie van de extra ruimte en bijbehorende gevelopeningen; materialisatie van de gevel (hout of metselwerk, veranda of luifel) wijkt mogelijk af van uw bouwnummer.

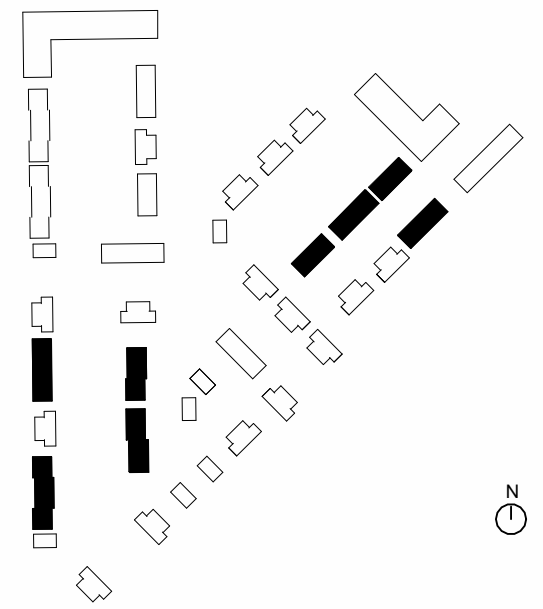

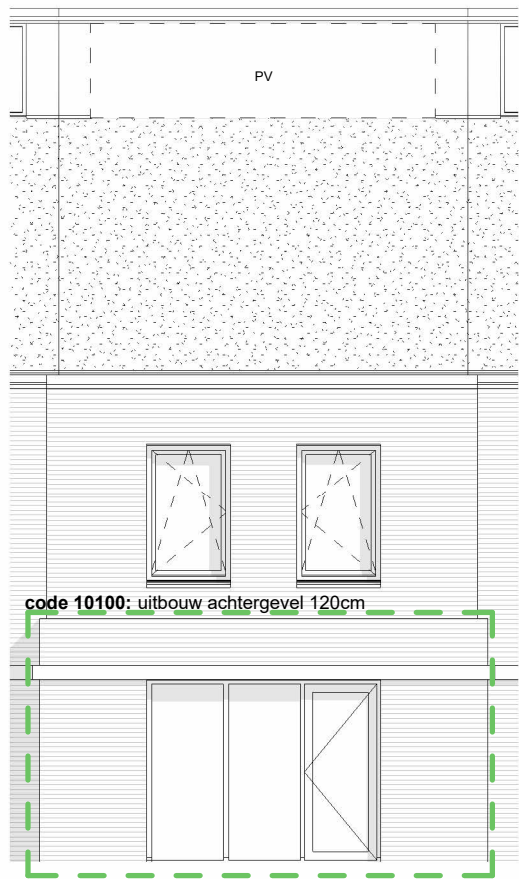

achtergevel

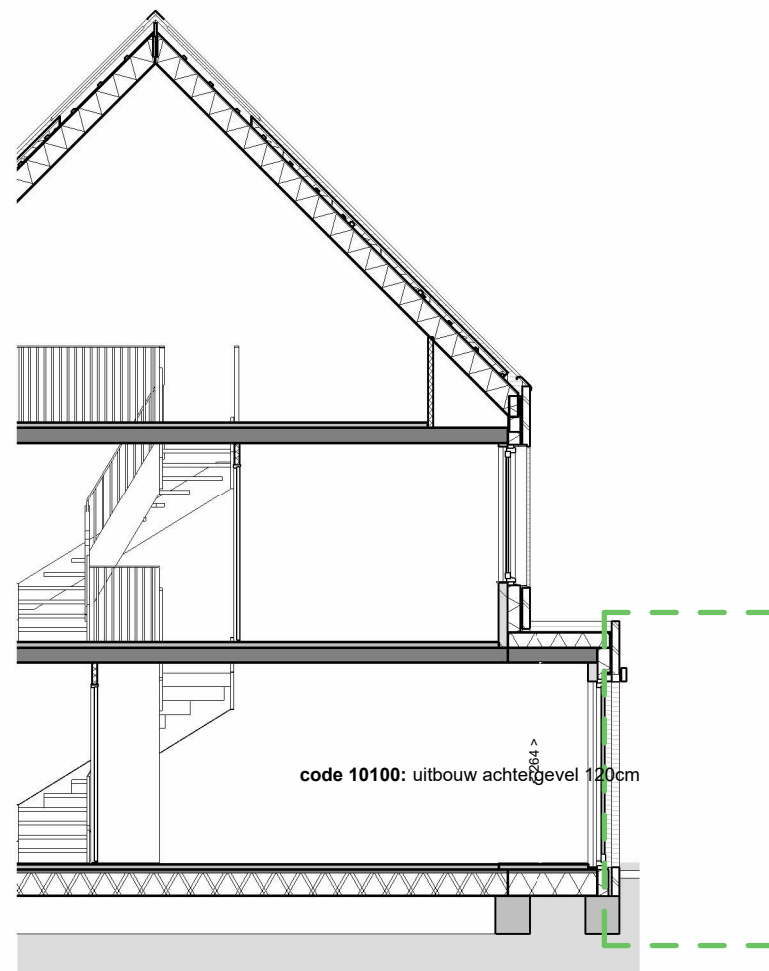

doorsnede

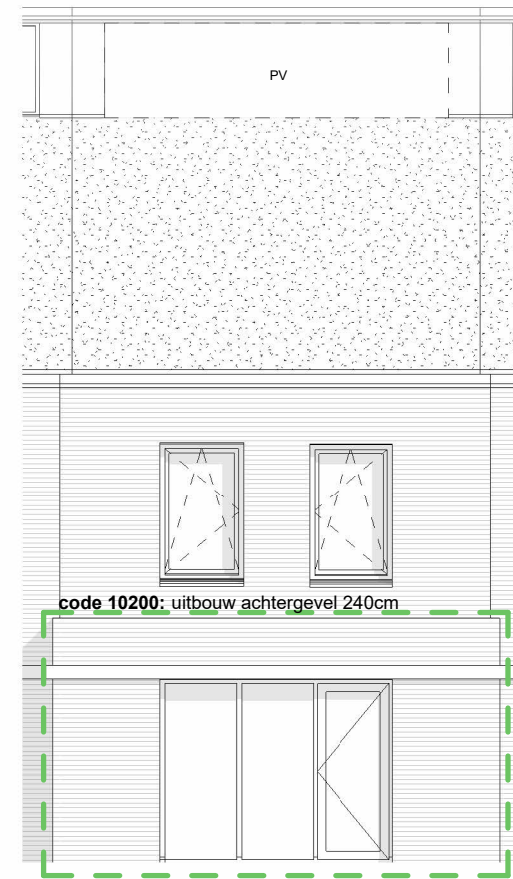

achtergevel

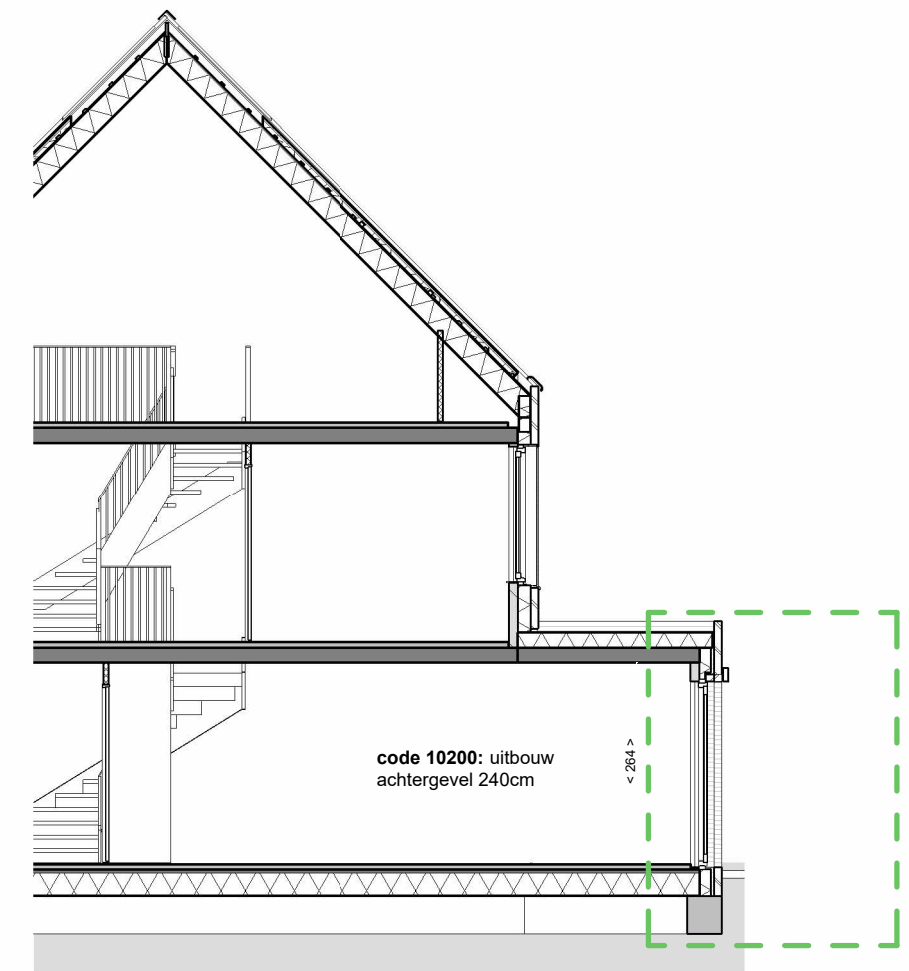

doorsnede

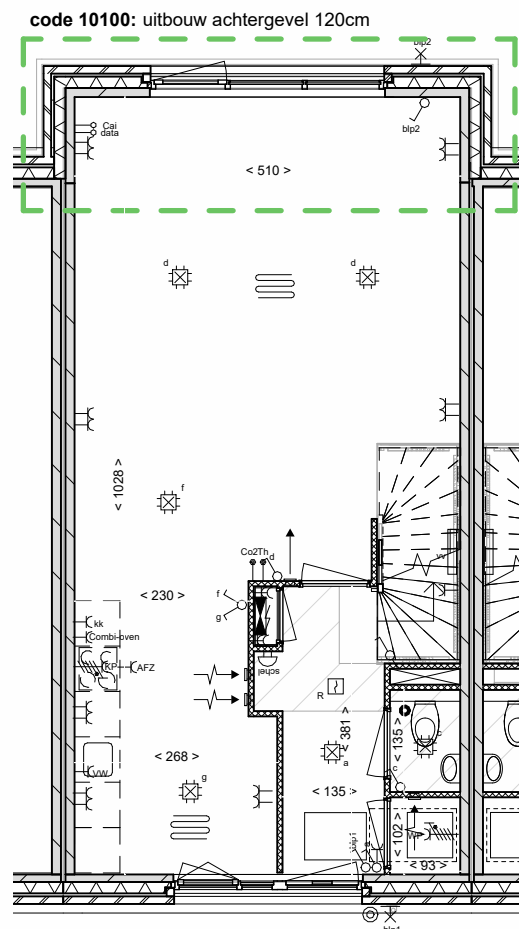

begane grond

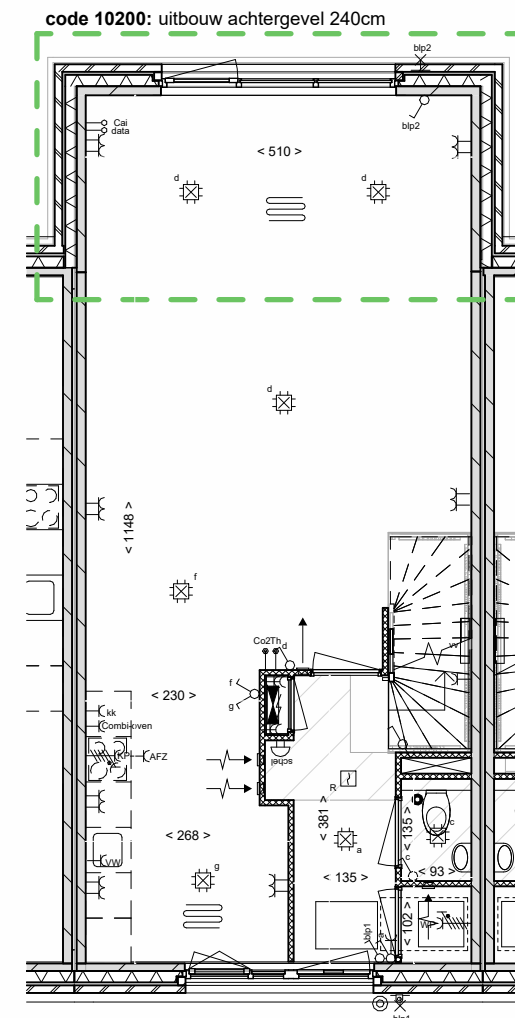

begane grond

**NB:**  
Kopersopties slechts ter indicatie van de extra ruimte en bijbehorende gevelopeningen; materialisatie van de gevel (hout of metselwerk, veranda of luifel) wijkt mogelijk af van uw bouwnummer.

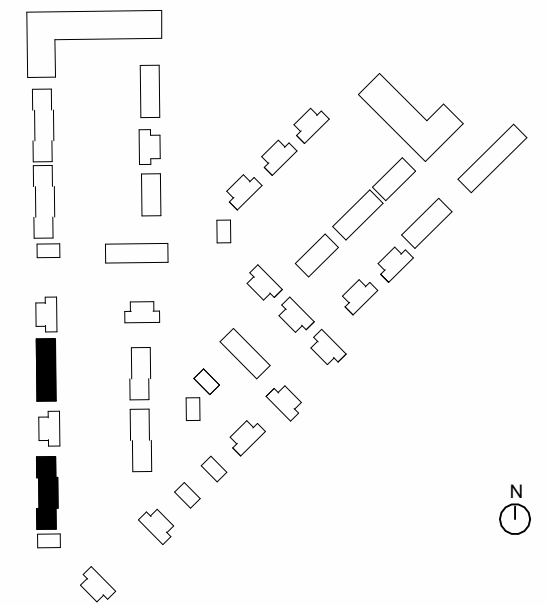

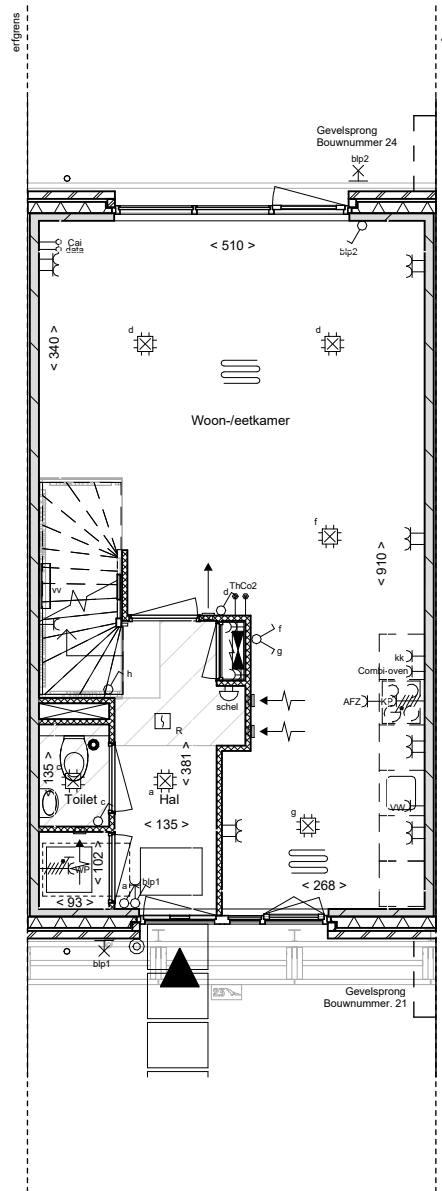

begane grond

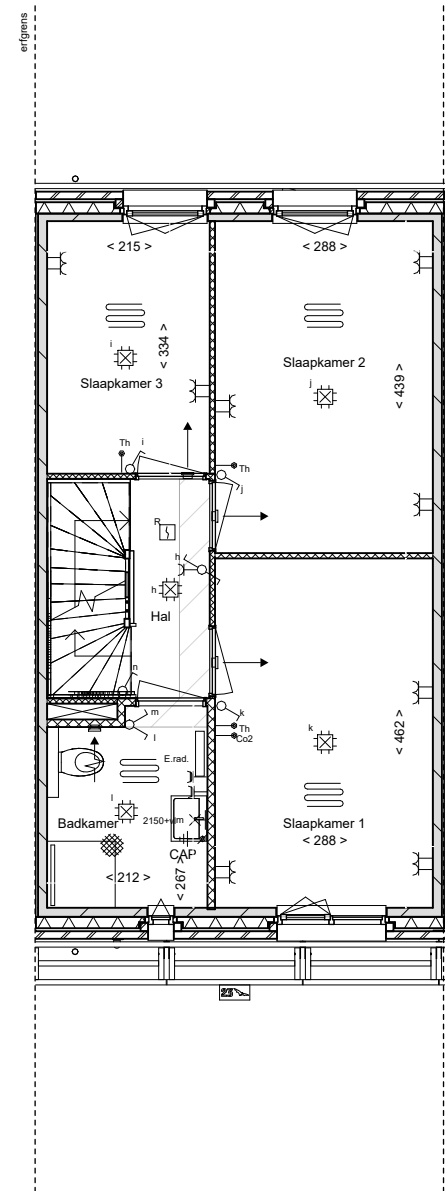

eerste verdieping

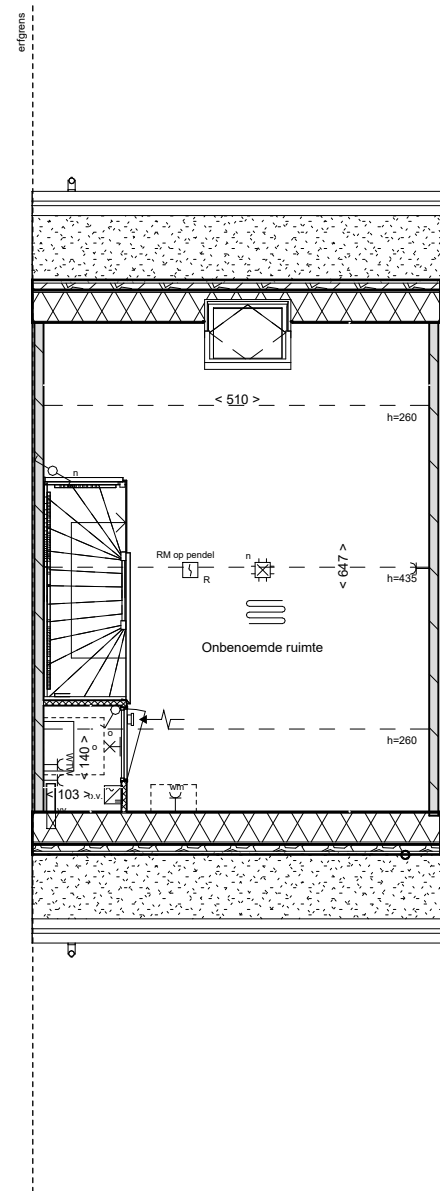

zolder

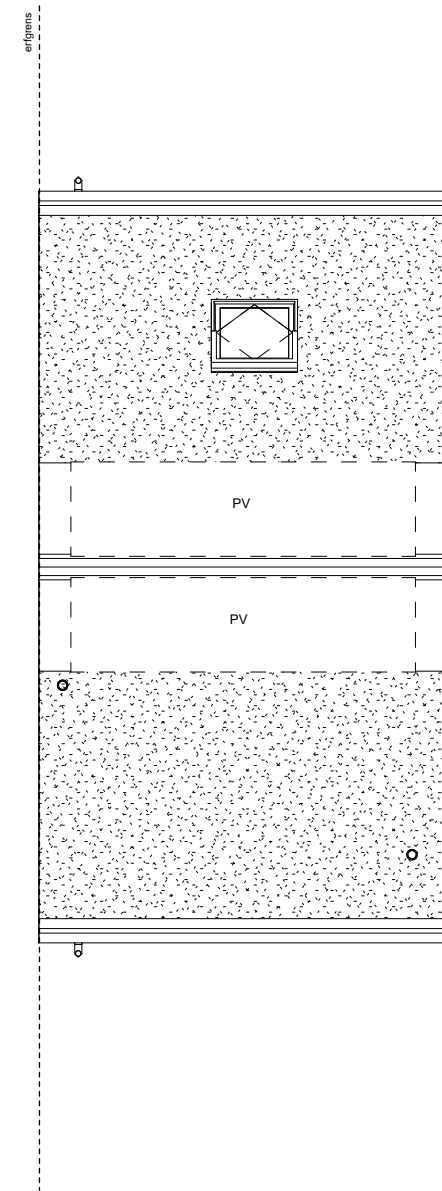

dakaanzicht

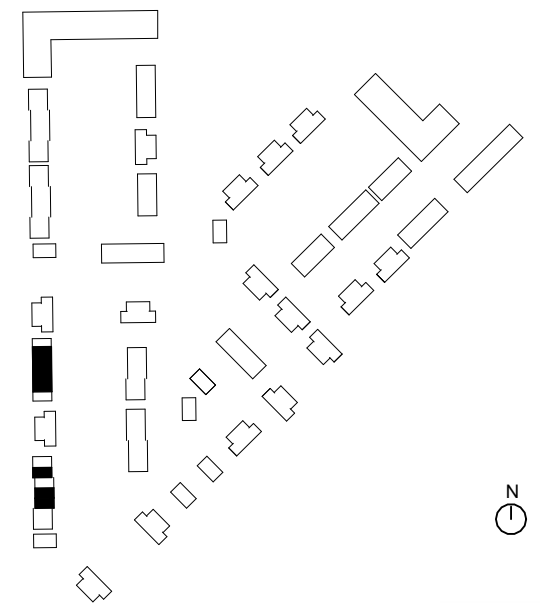



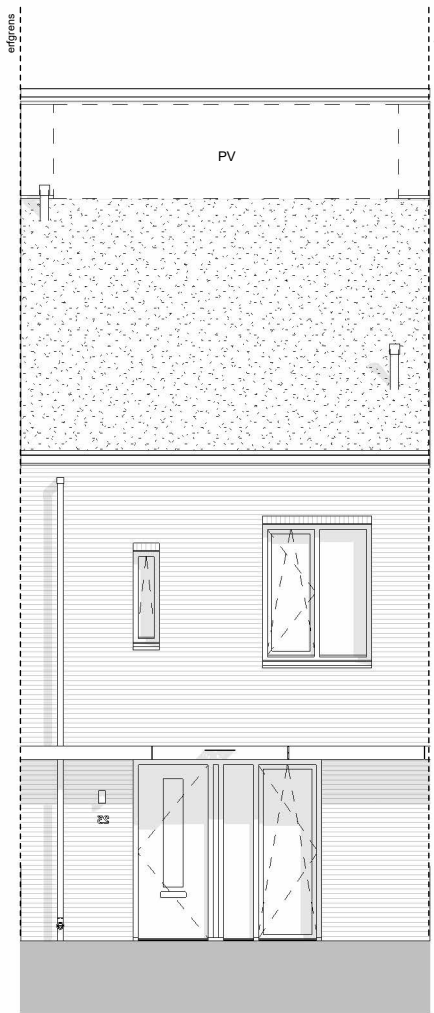

voorgevel

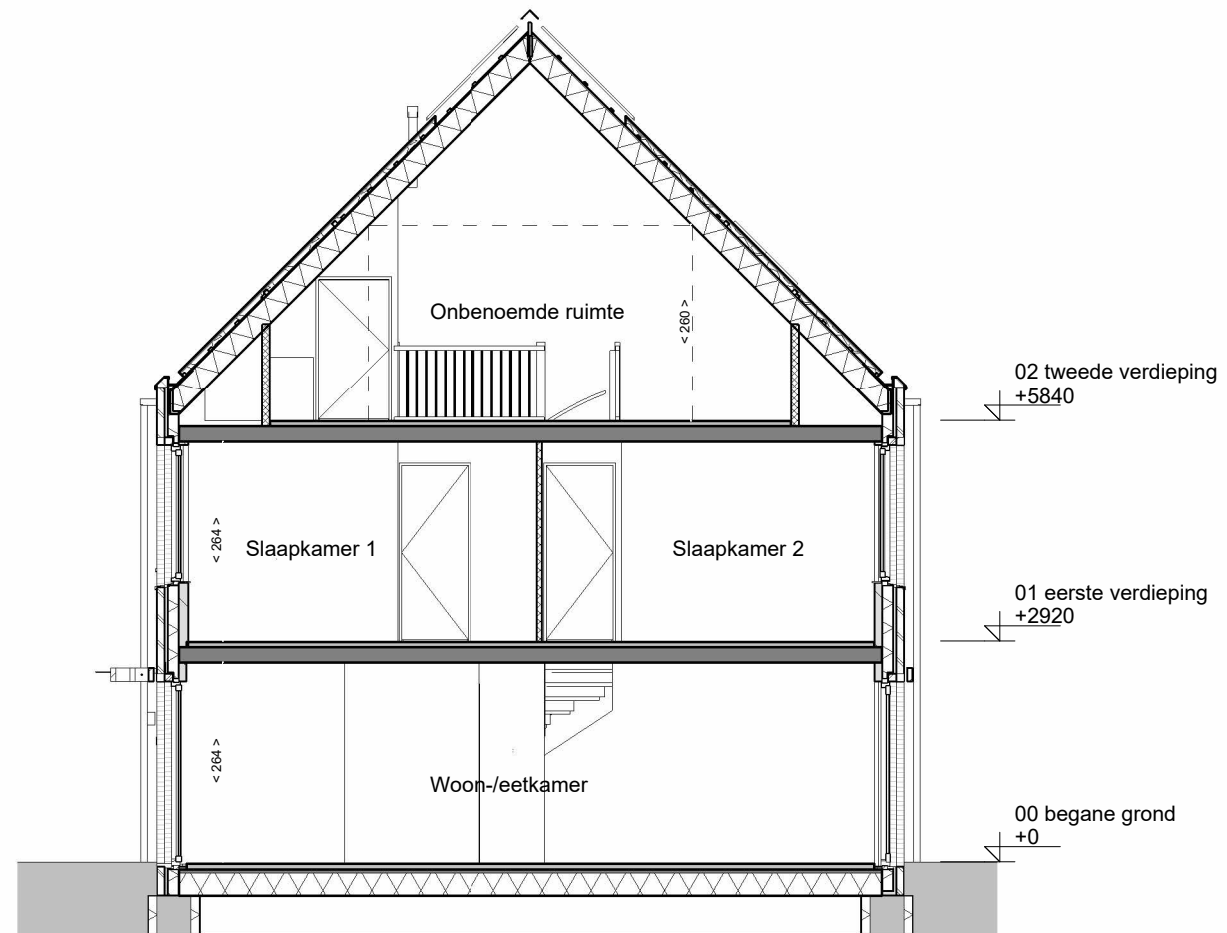

doorsnede

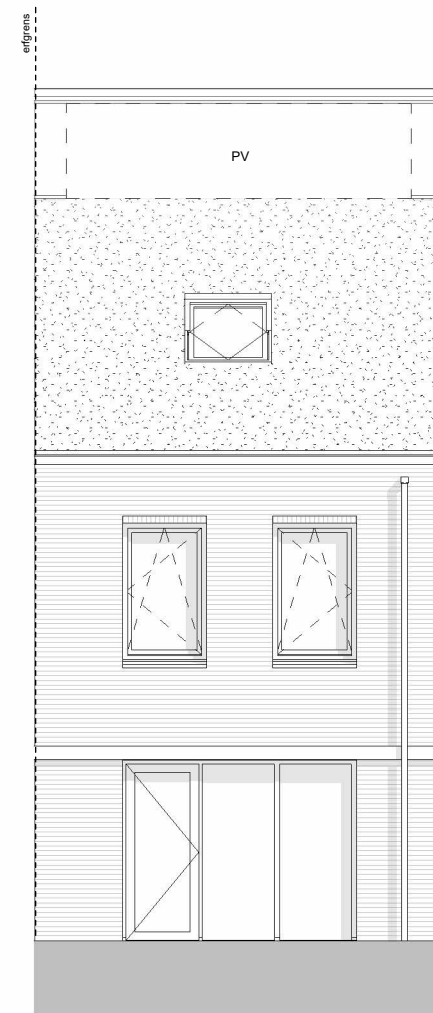

achtergevel

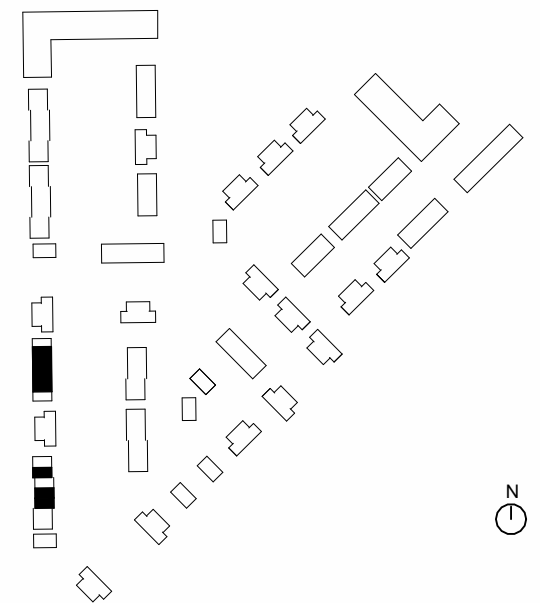

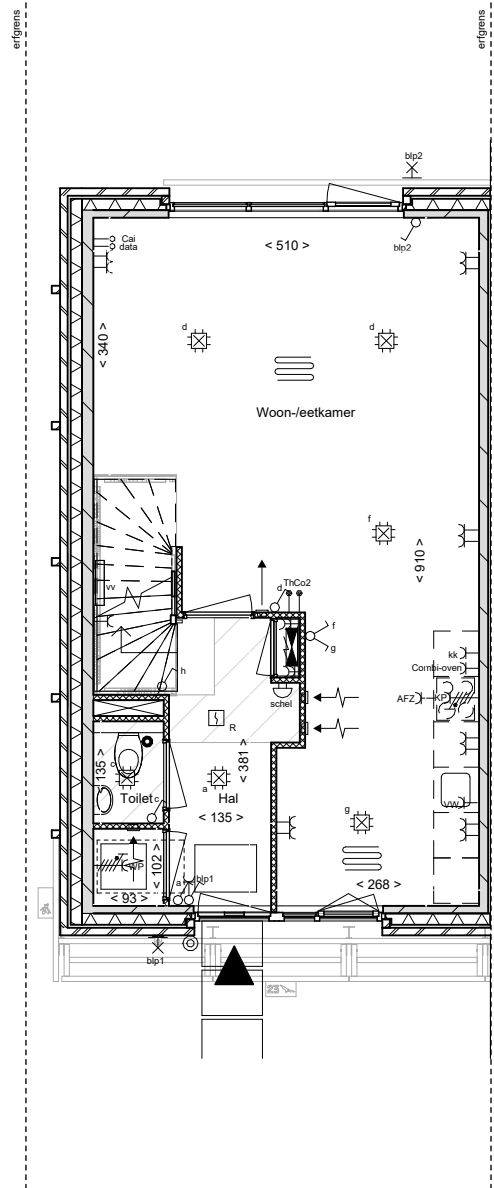

begane grond

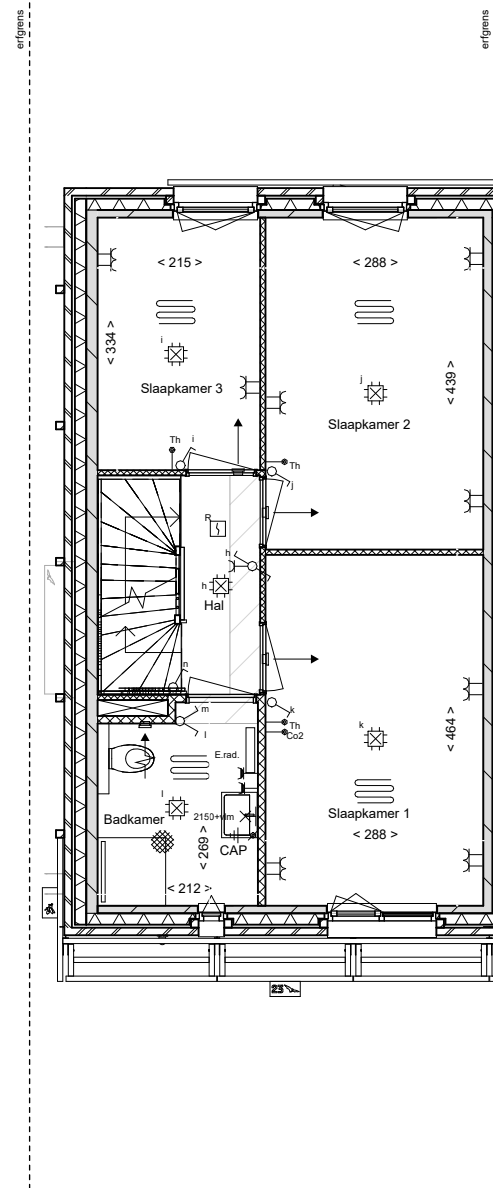

eerste verdieping

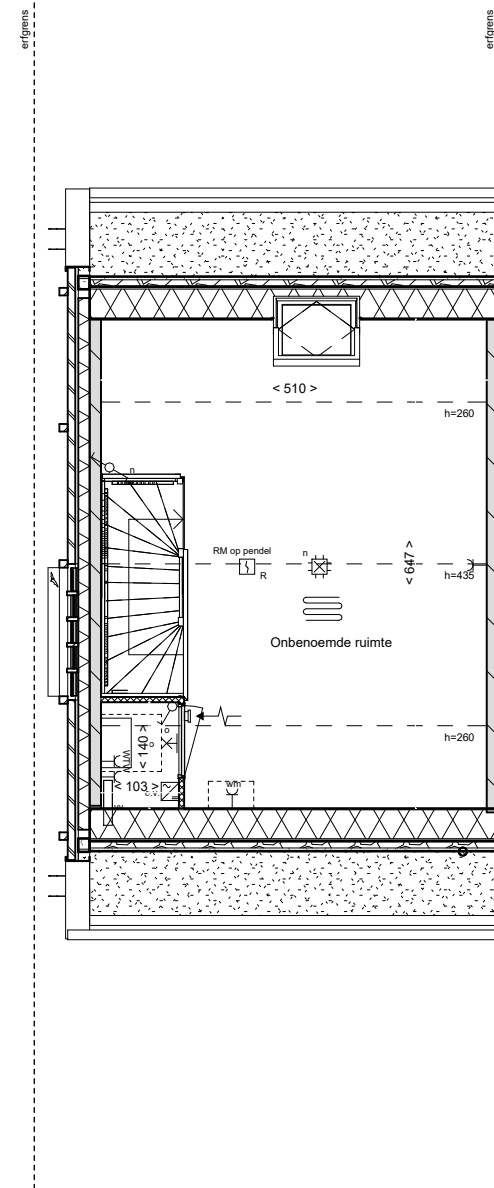

zolder

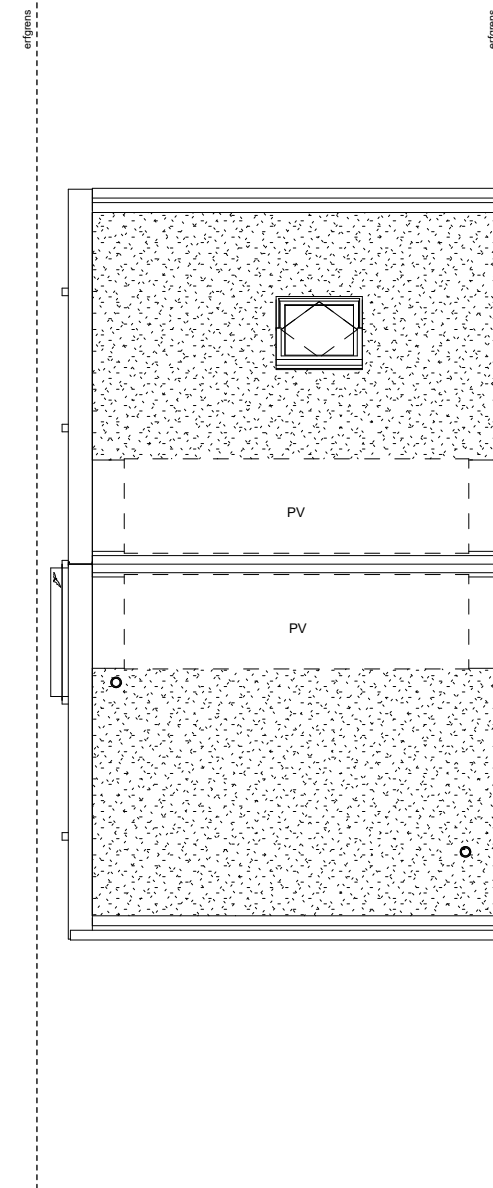

dakaanzicht

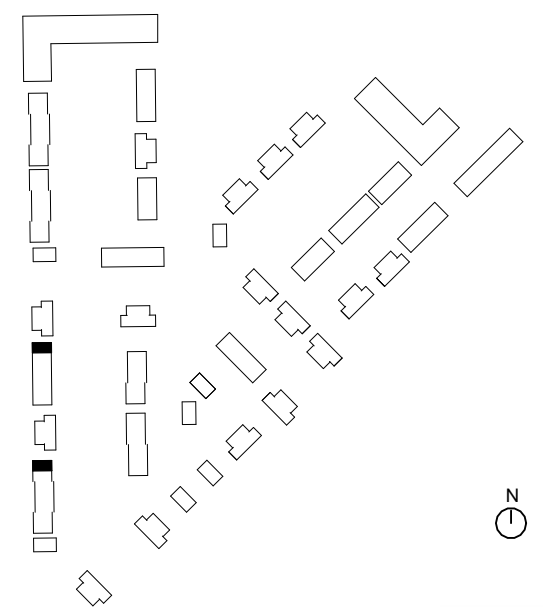

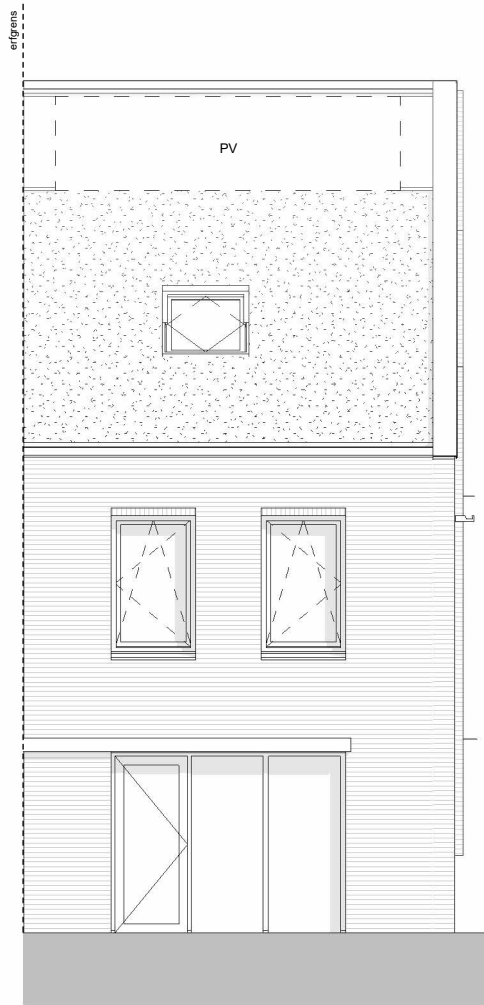

achtergevel

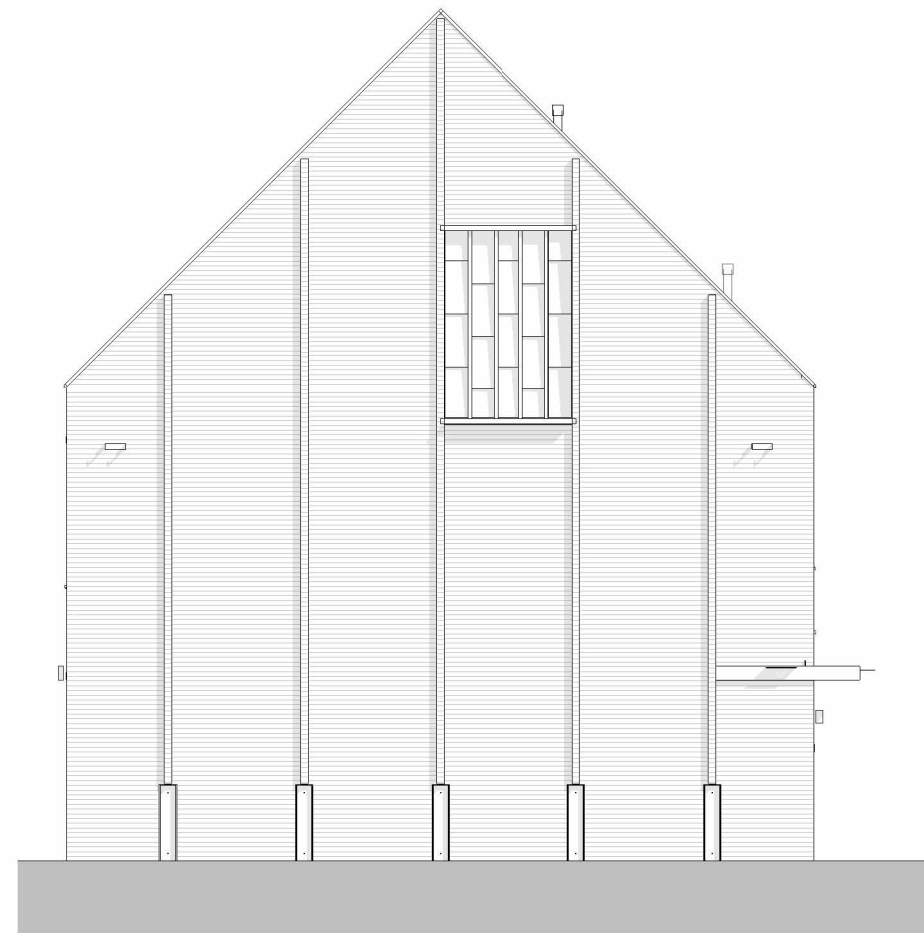

kopgevel met vloermuiskasten



voorgevel

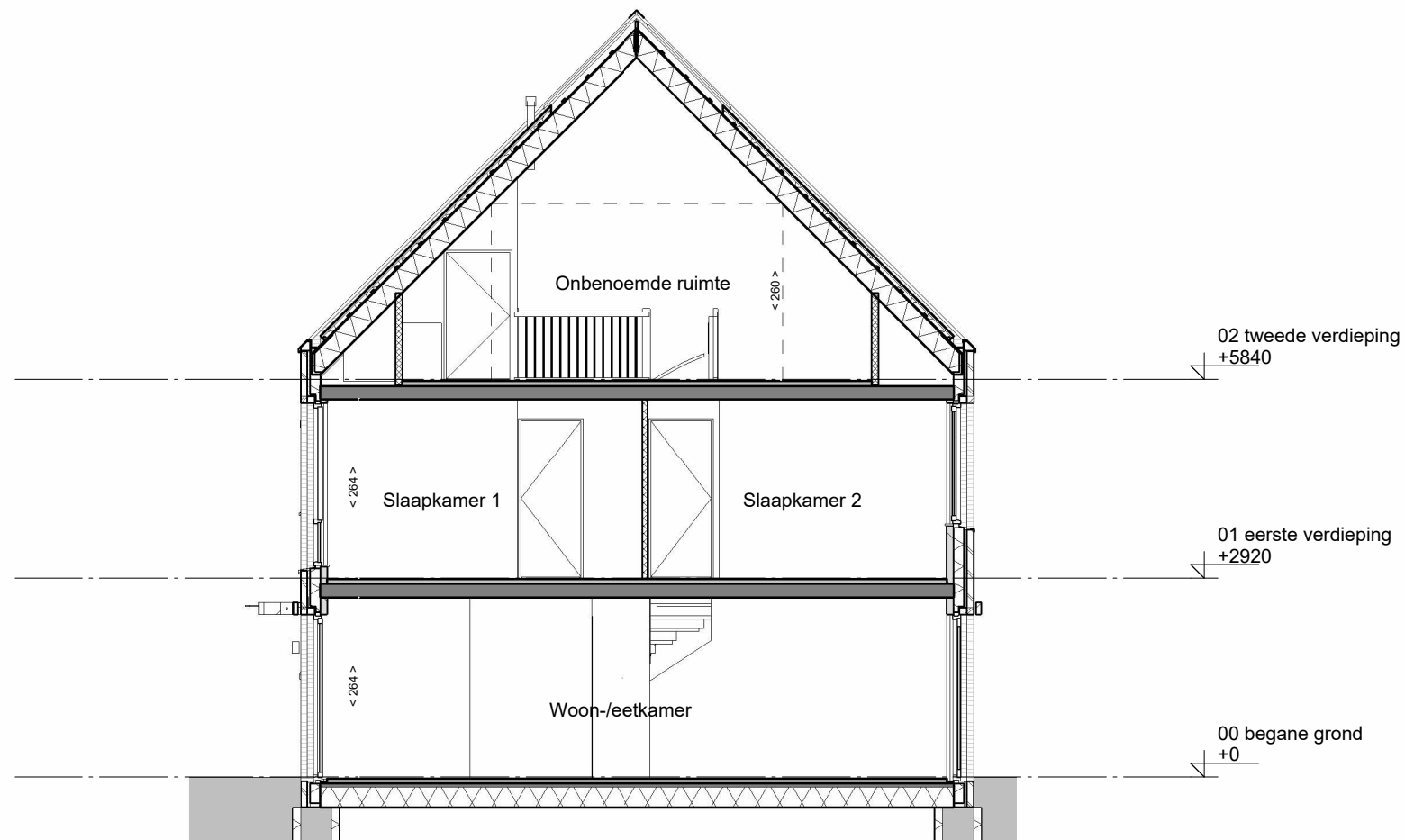

doorsnede

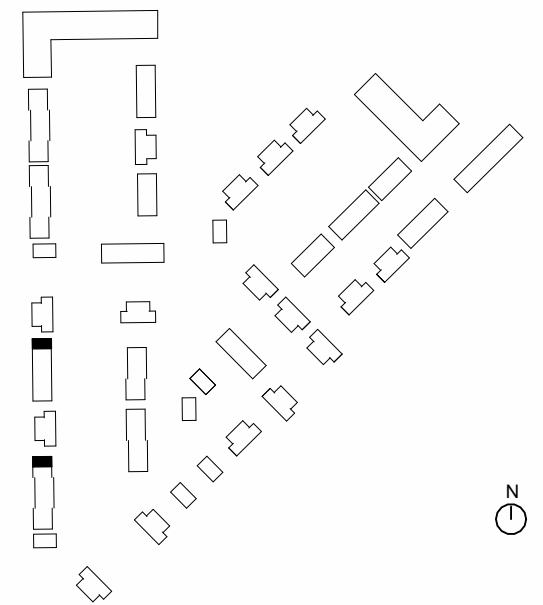

Omschrijving  
**Gevelaanzichten en doorsneden voorlopig**

Onderdeel Verkooptekening	tekeningnummer <b>VK-025-2</b>	getekend	schaal	formaat
Bouwnummer(s) 25 & 33	-	-	1 : 100	A3

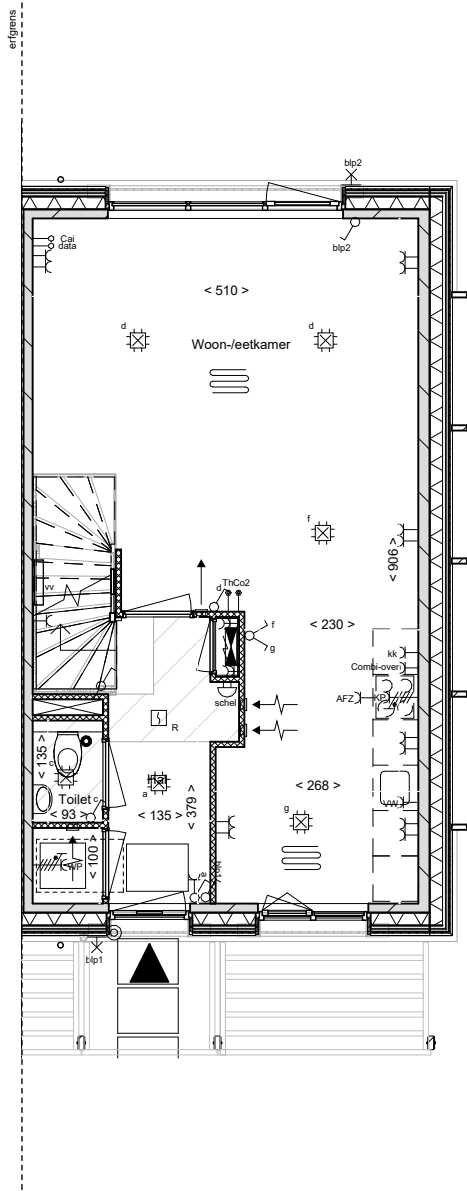

begane grond

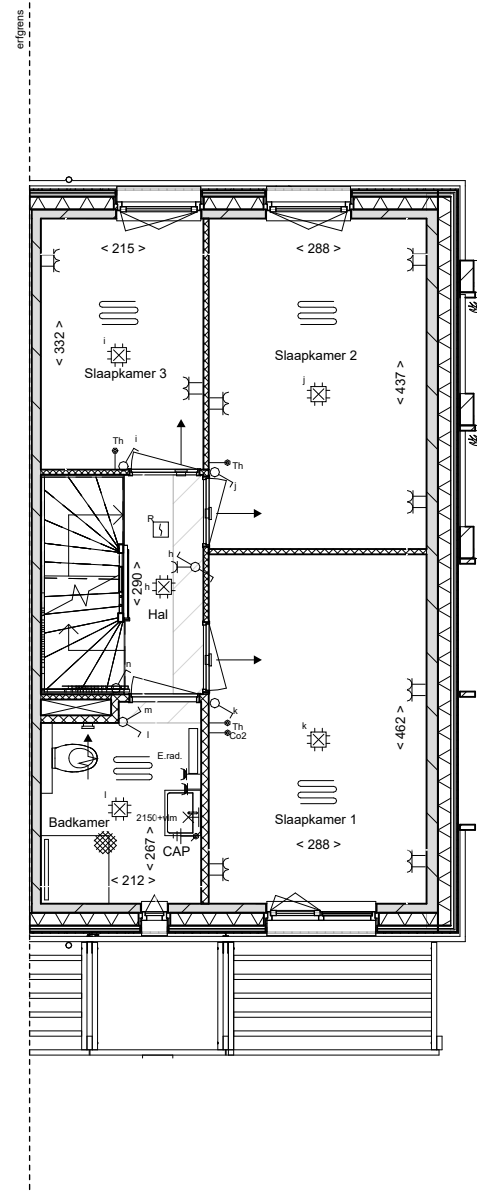

eerste verdieping

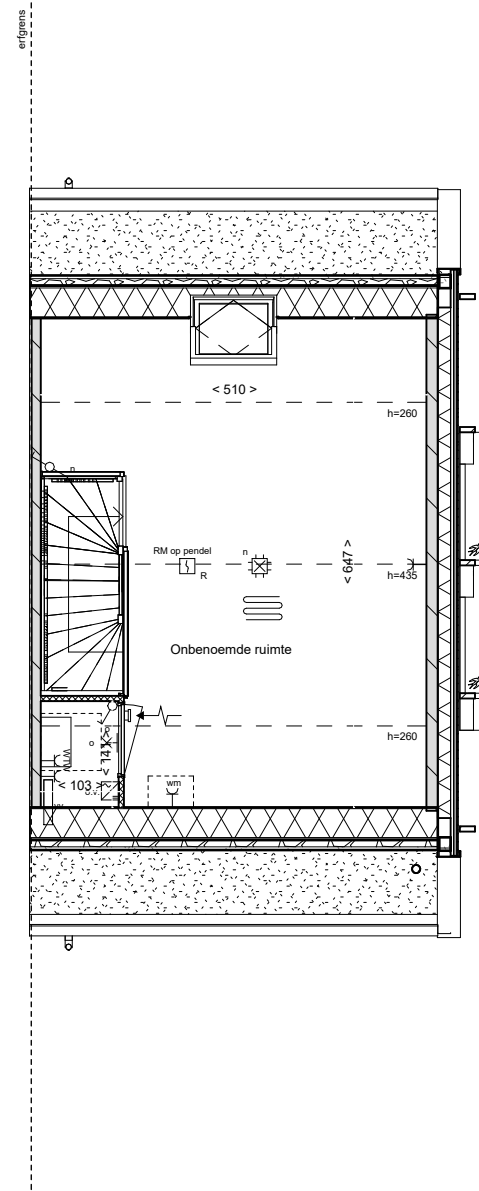

zolder

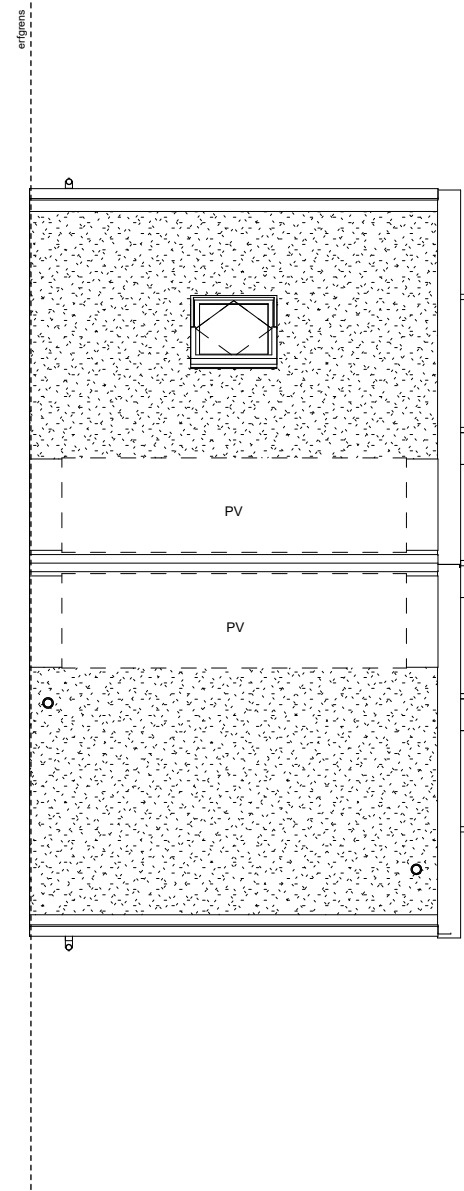

dakaanzicht

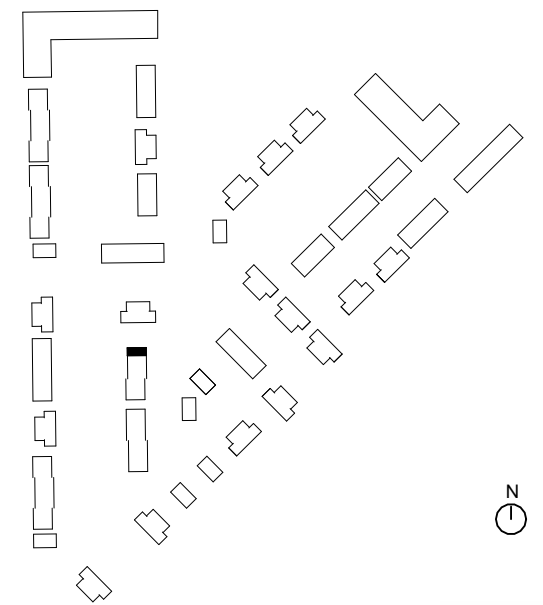

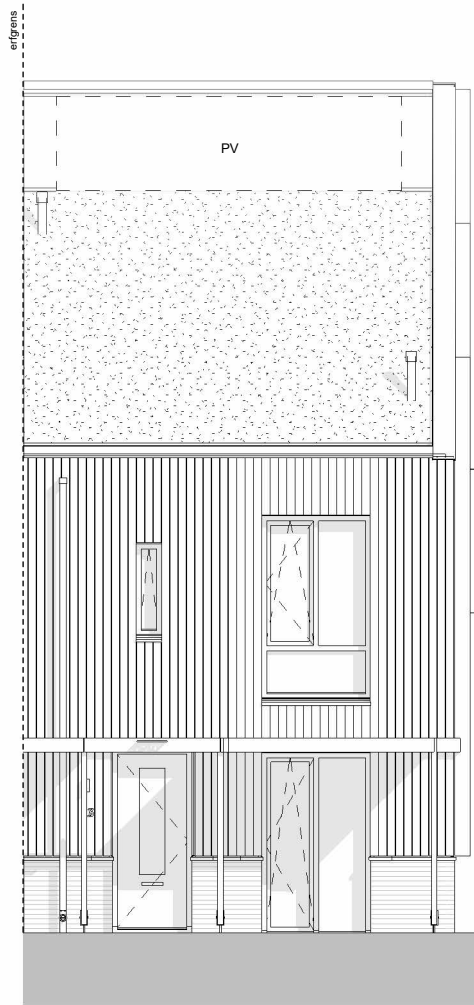

voorgevel

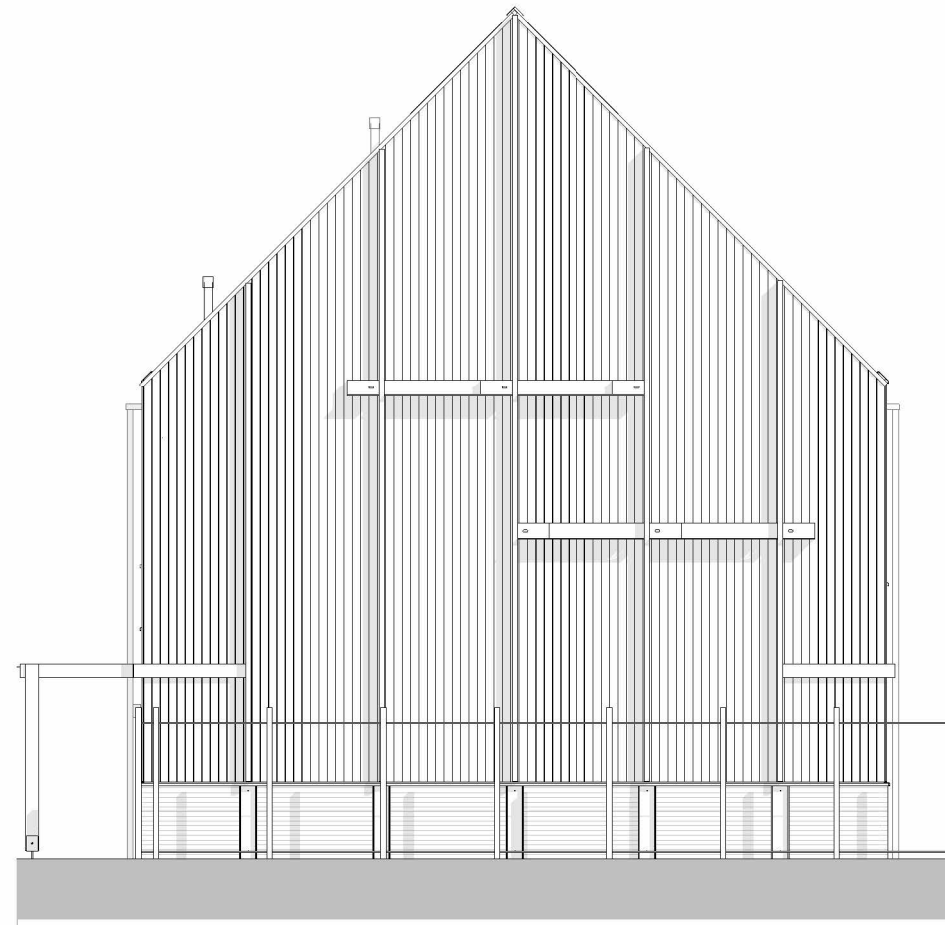

kopgevel gierzwaluw kasten

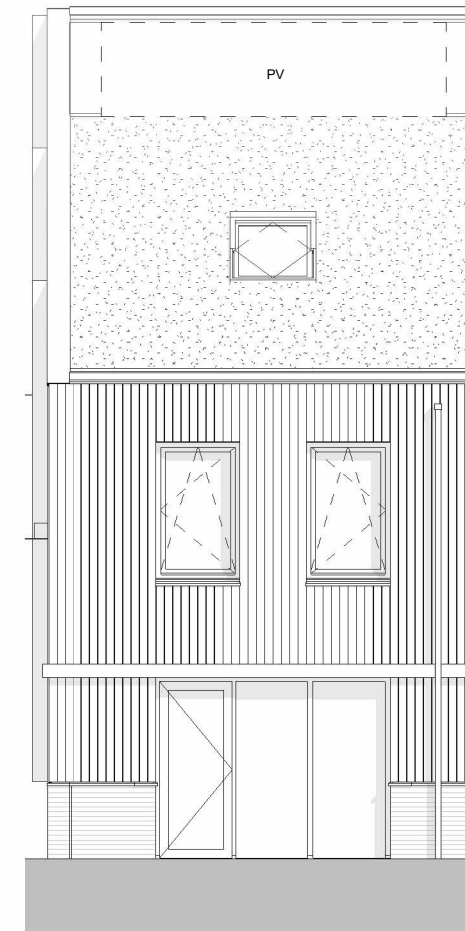

achtergevel

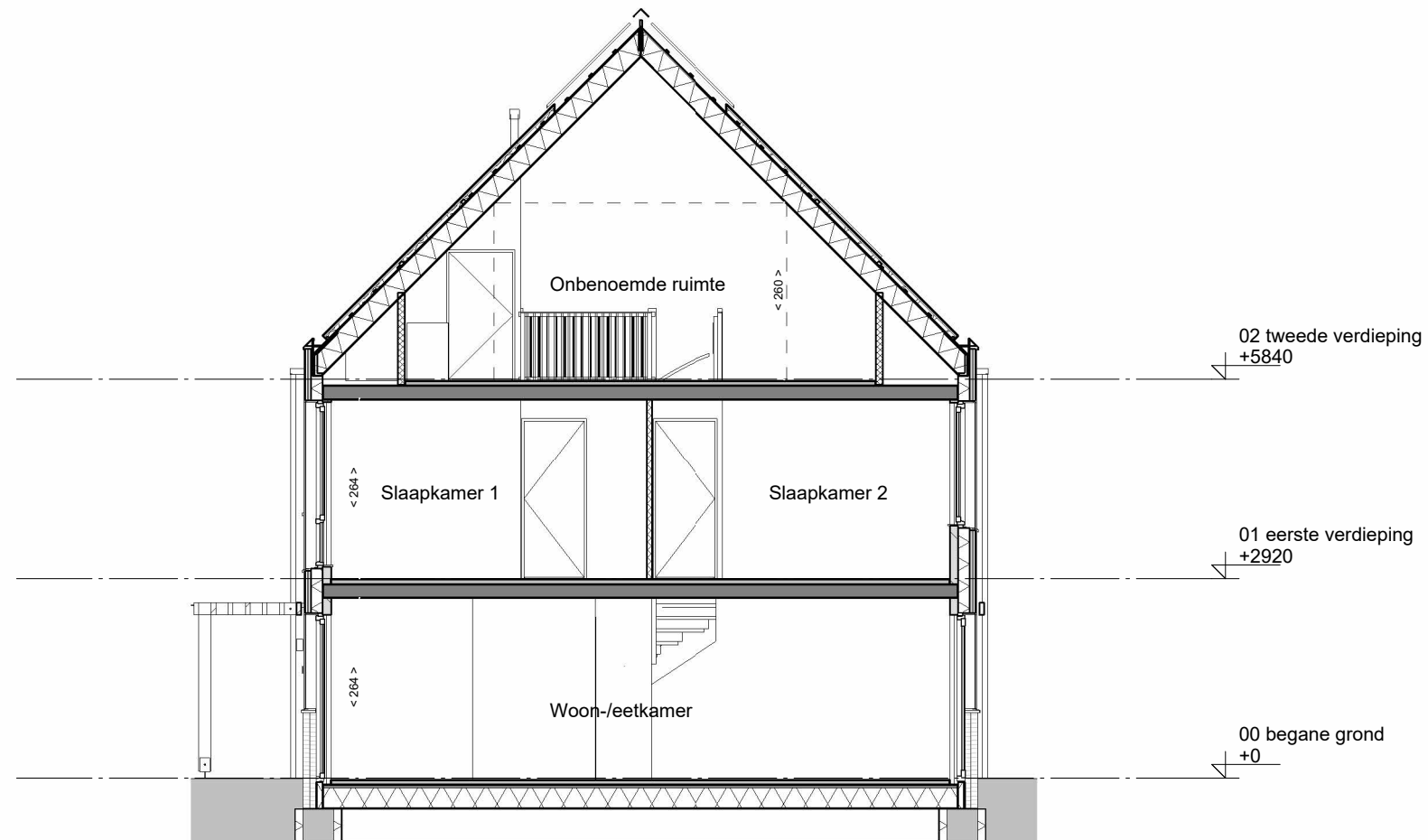

doorsnede

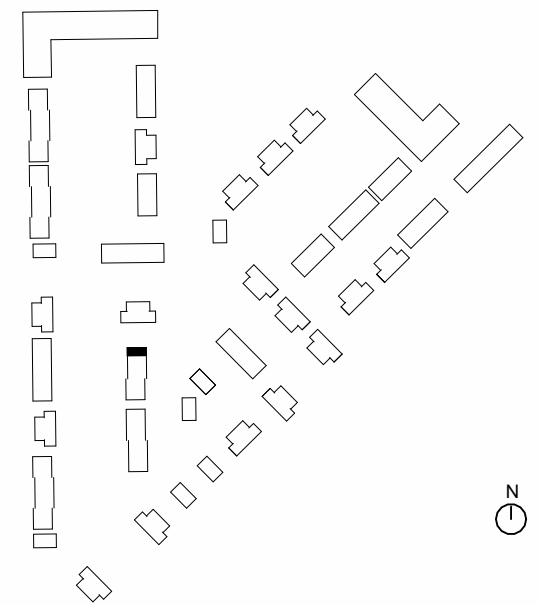

Omschrijving  
**Gevelaanzichten en doorsneden voorlopig**

Onderdeel Verkooptekening	tekeningnummer <b>VK-070-2</b>	getekend	schaal	formaat
Bouwnummer(s) 70	-	-	1 : 100	A3

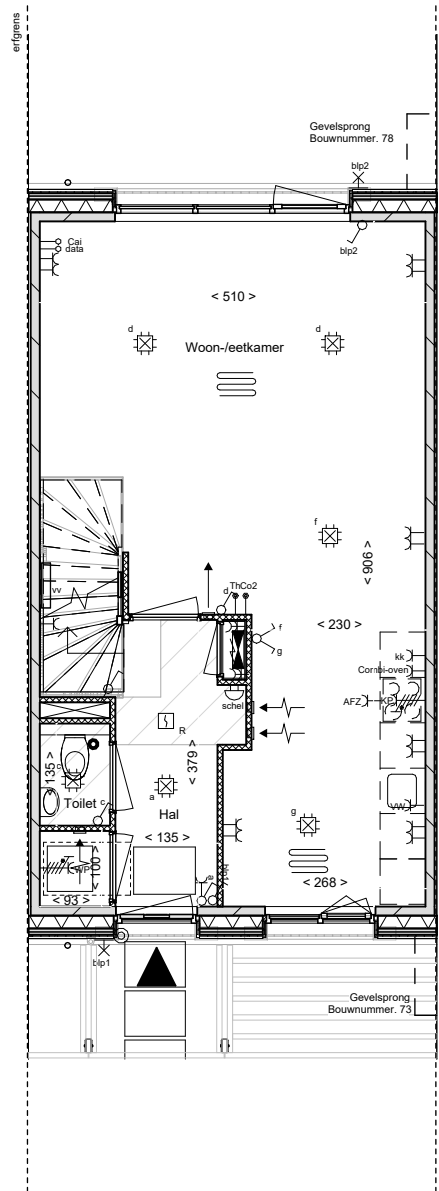

begane grond

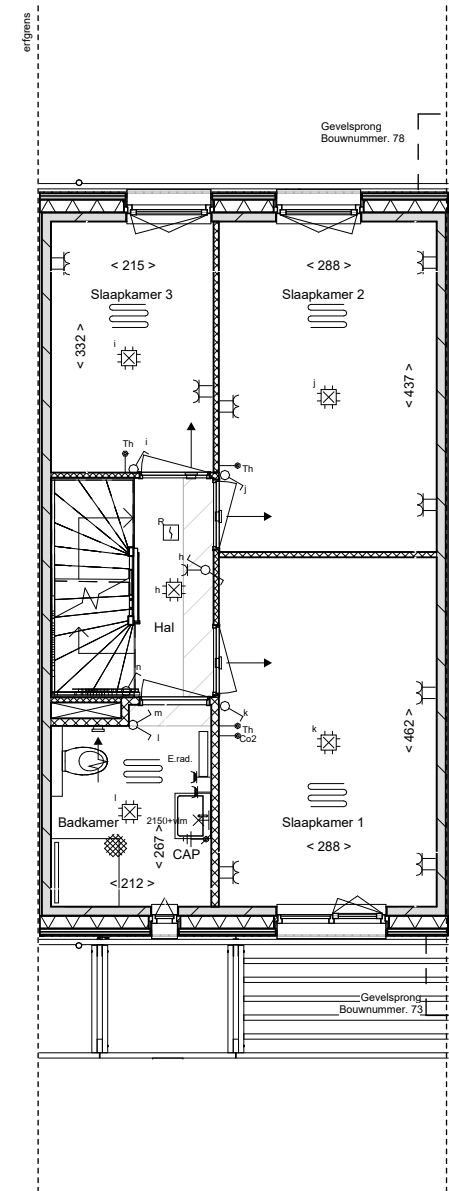

eerste verdieping

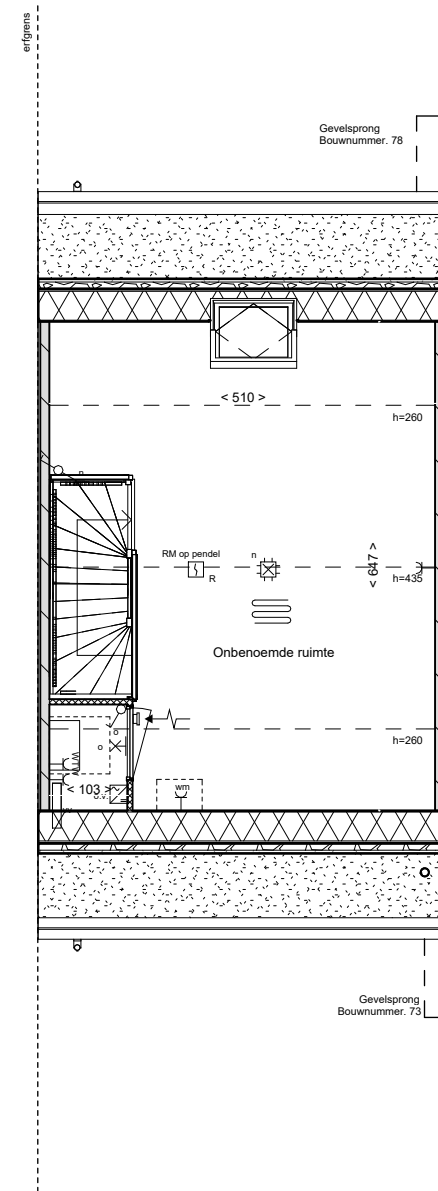

zolder

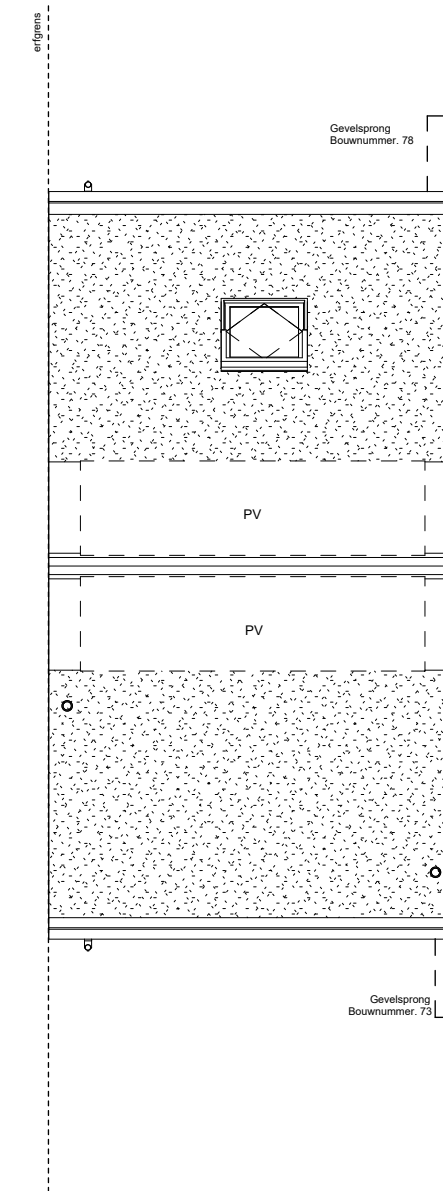

dakaanzicht

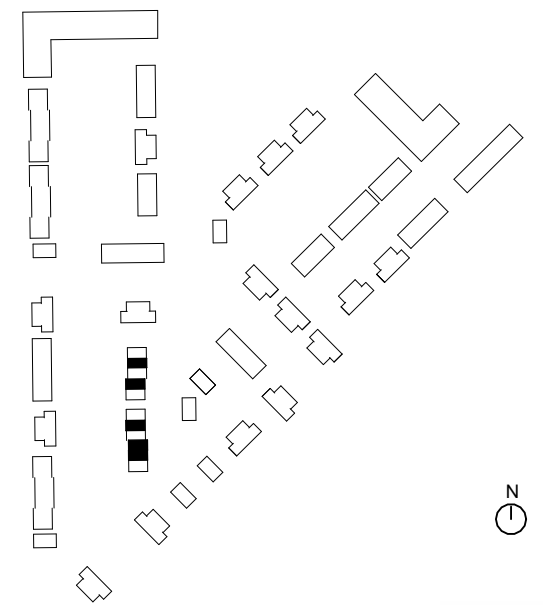

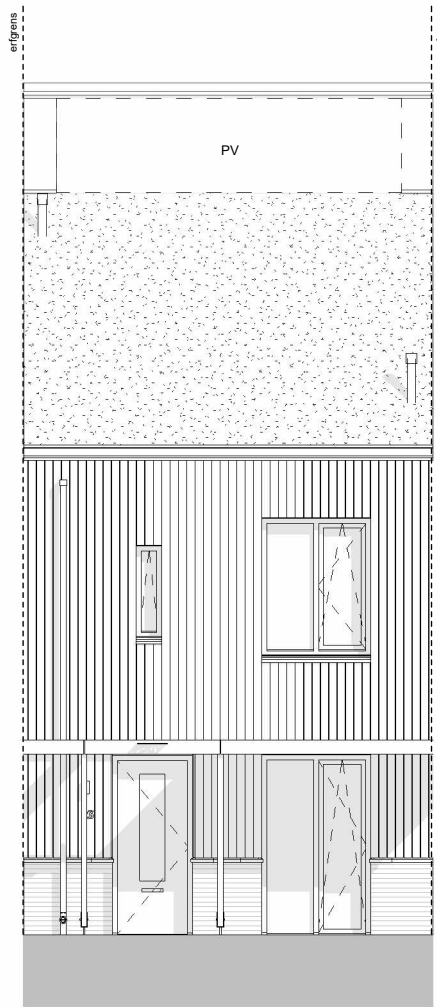

voorgevel

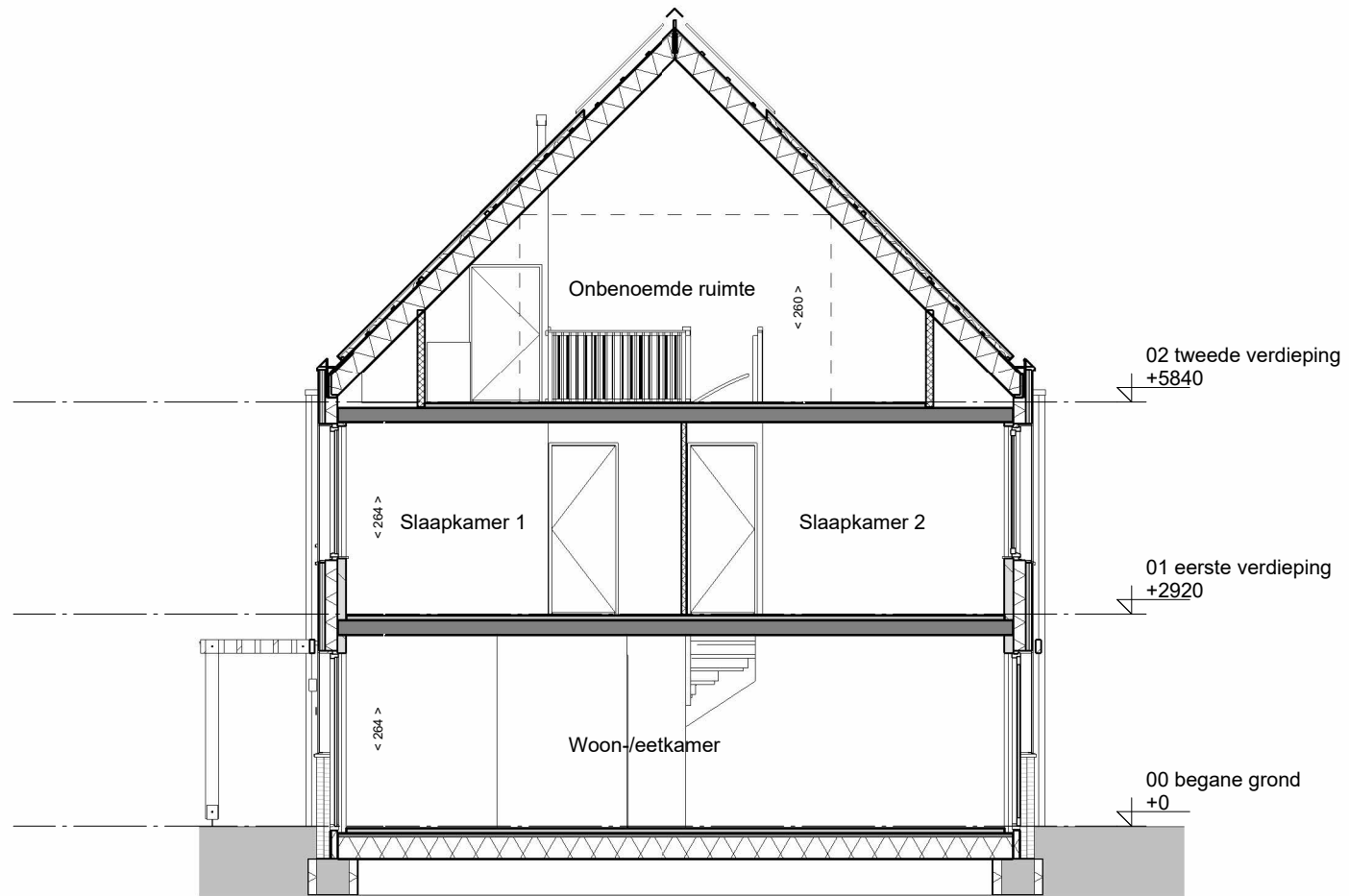

doorsnede

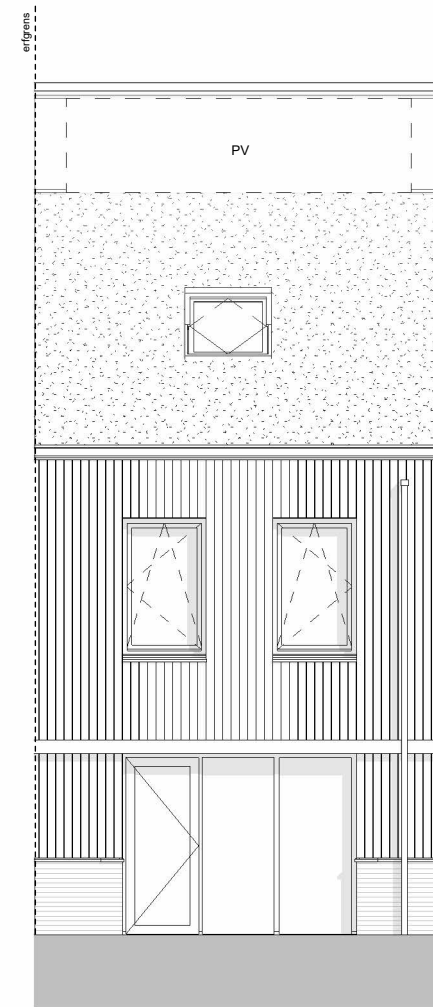

achtergevel

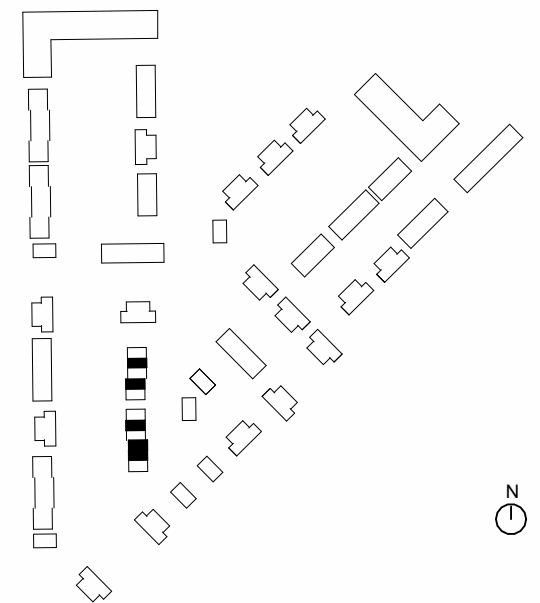

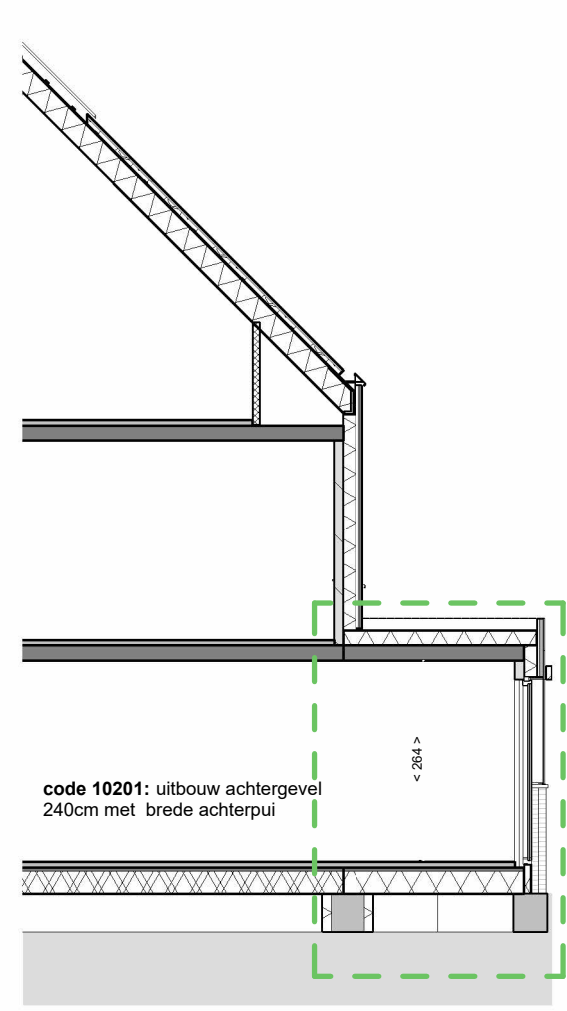
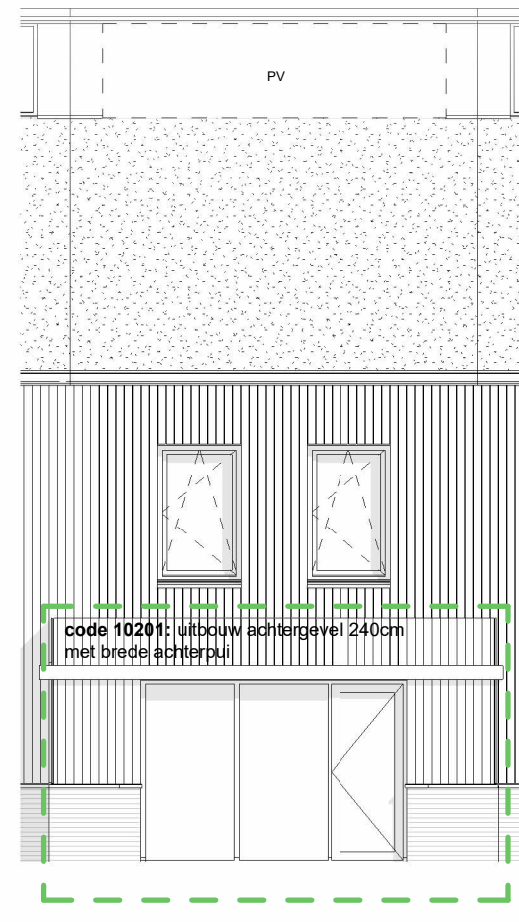
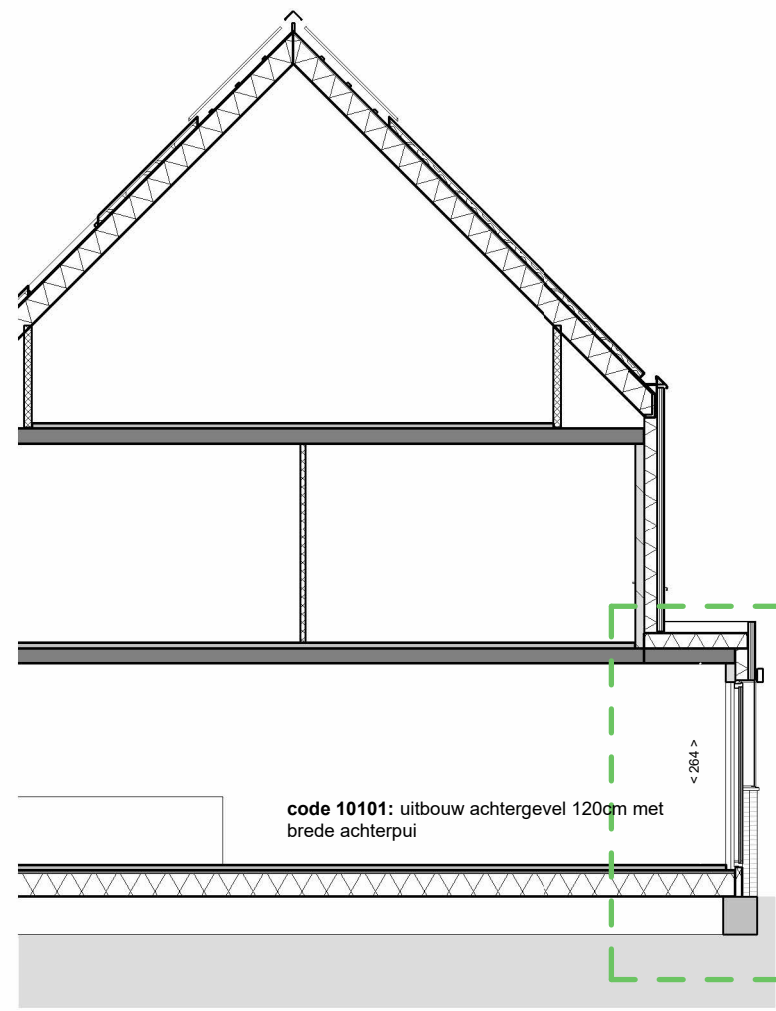
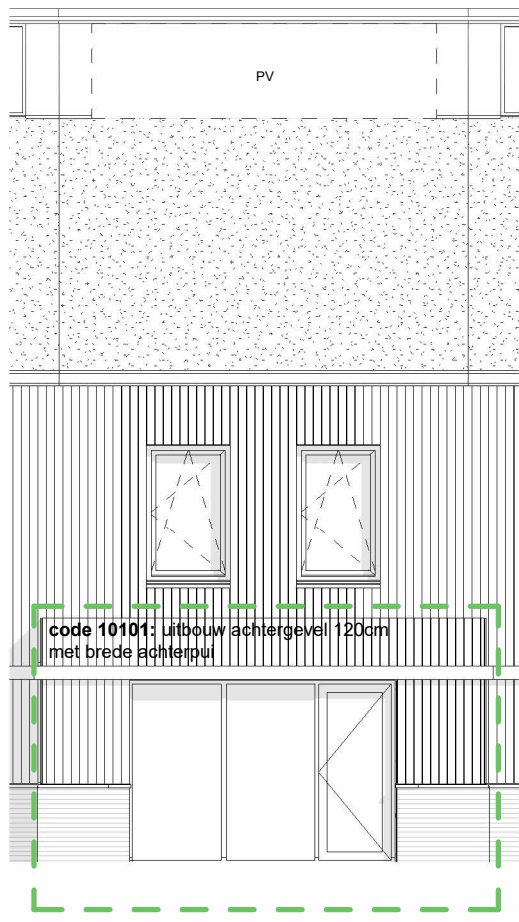

achtergevel

doorsnede

achtergevel

doorsnede

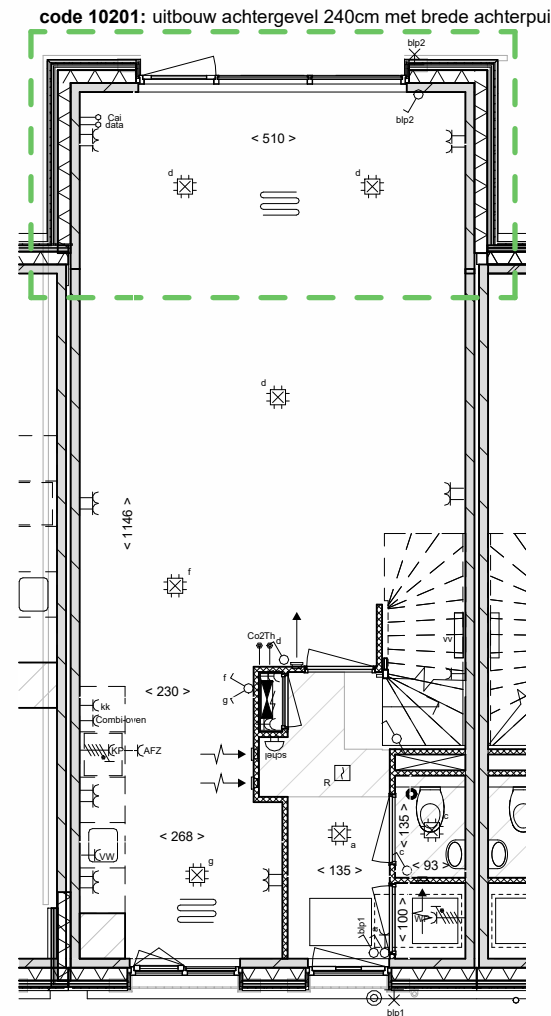
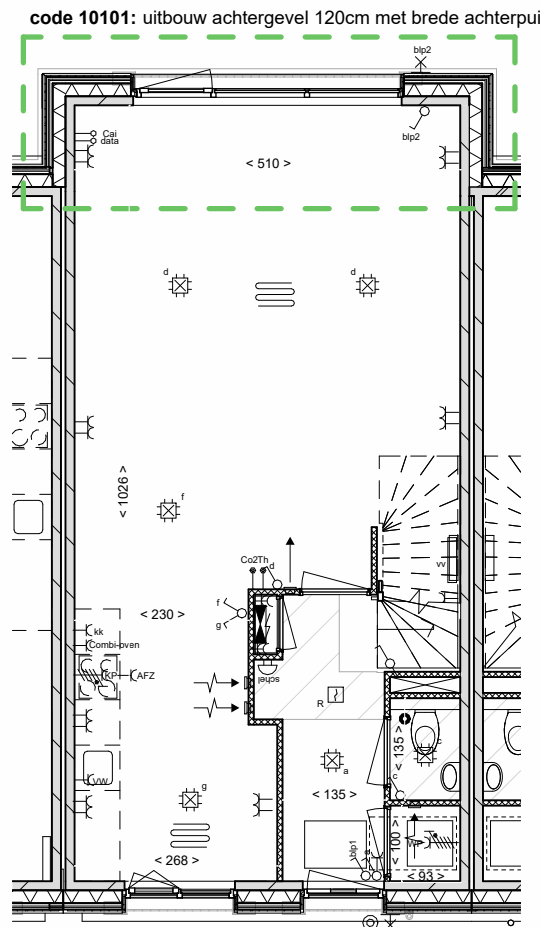

begane grond

begane grond

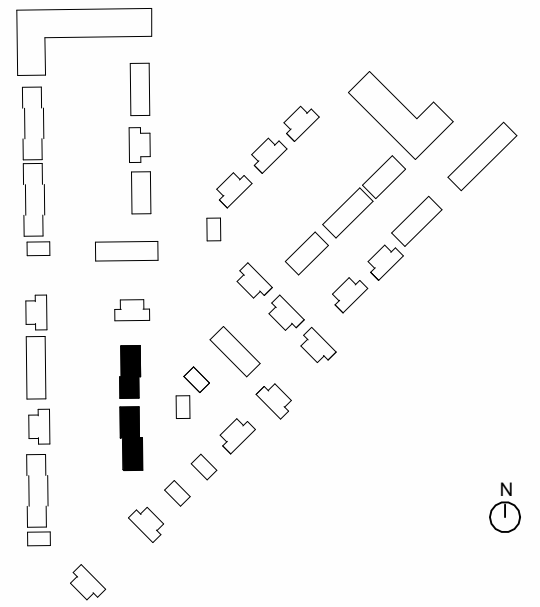

Omschrijving  
Kopersoptie uitbouw

voorlopig

Onderdeel  
Verkooptekening  
Bouwnummer(s)  
70 t/m 80

tekeningnummer  
VK-071-3  
getekend  
-

schaal  
1 : 100  
formaat  
A3



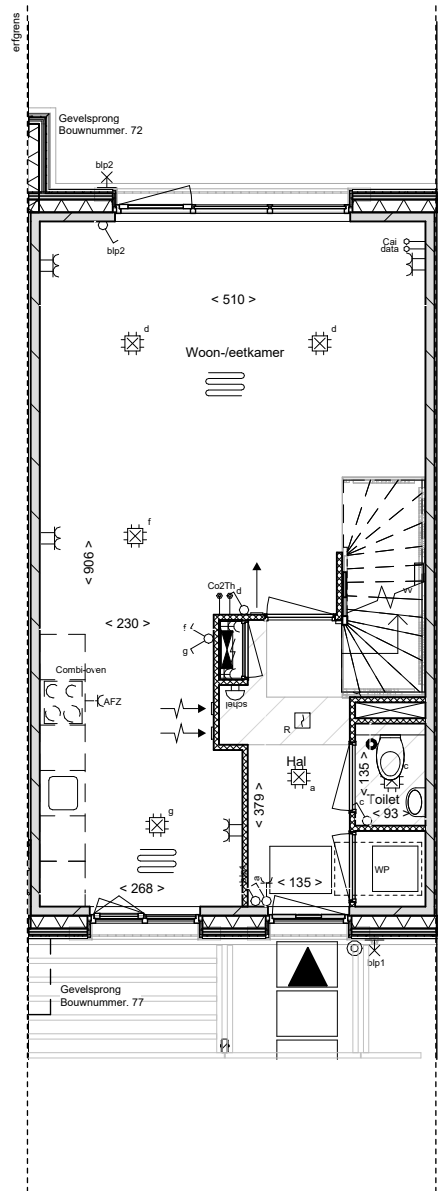

begane grond

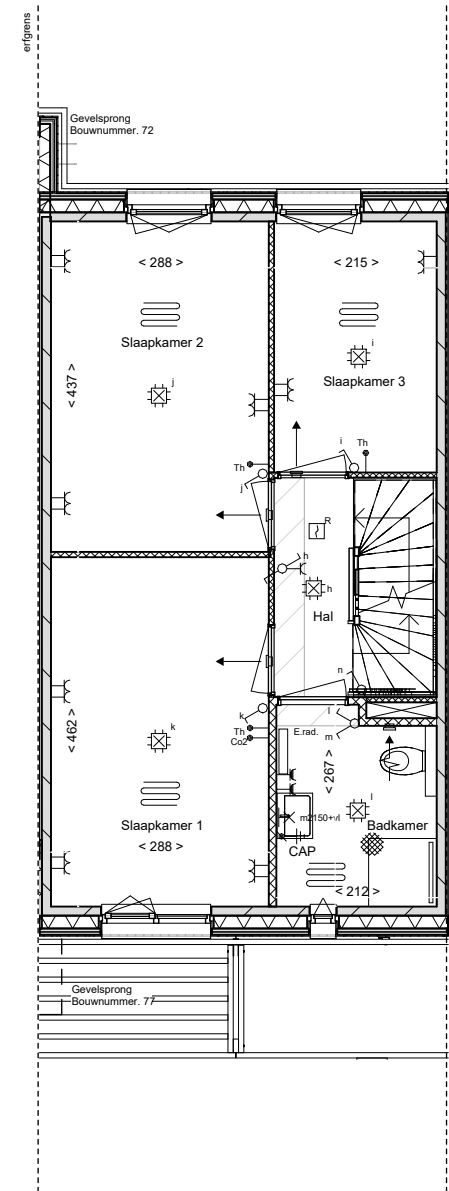

eerste verdieping

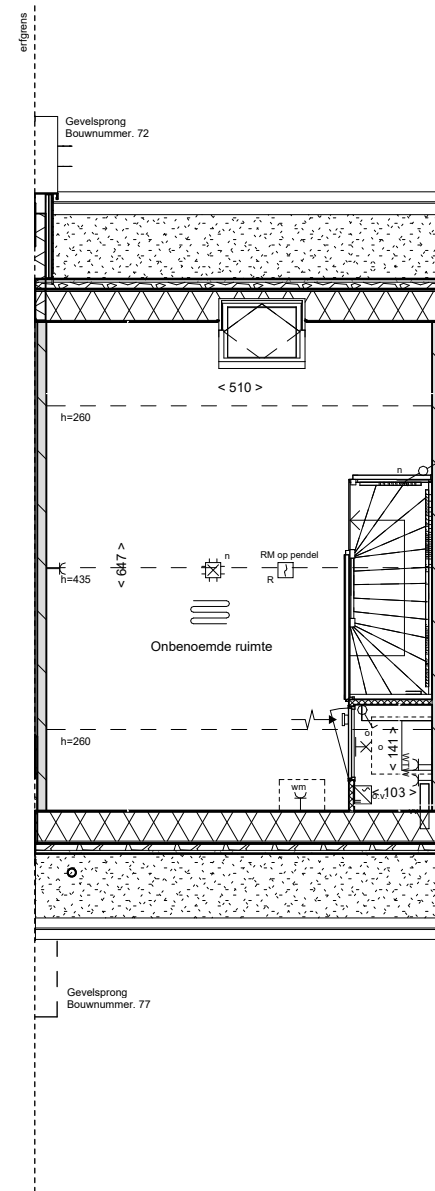

zolder

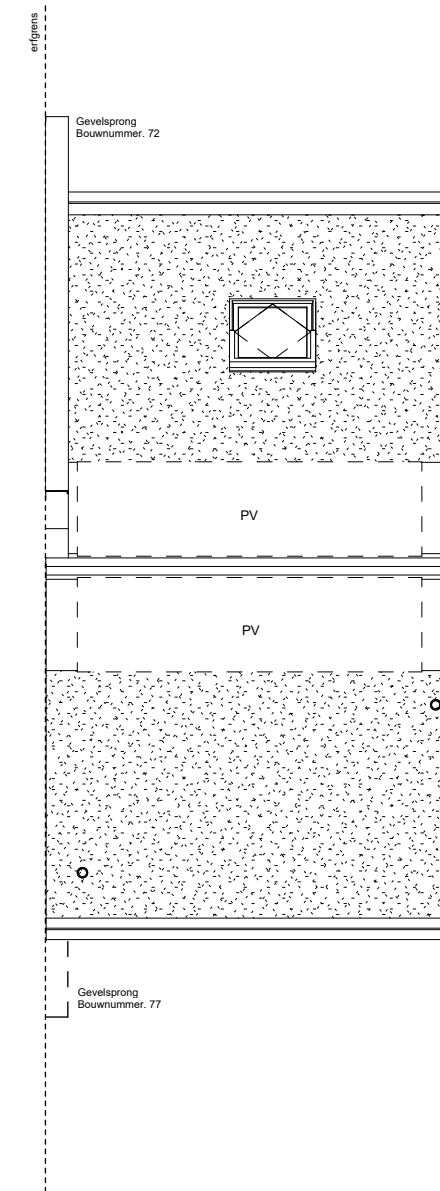

dakaanzicht

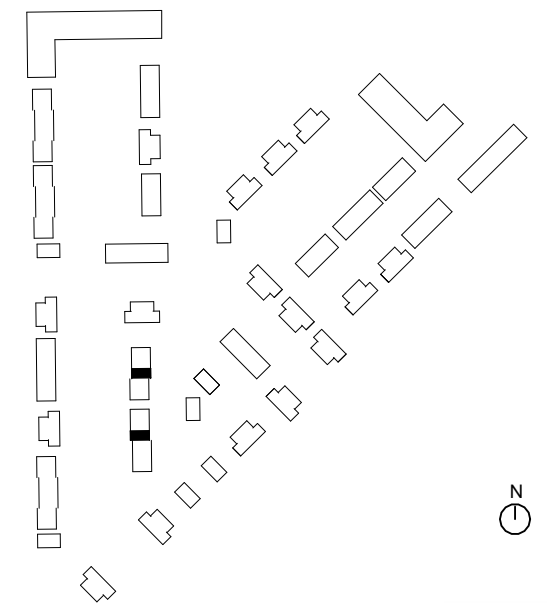

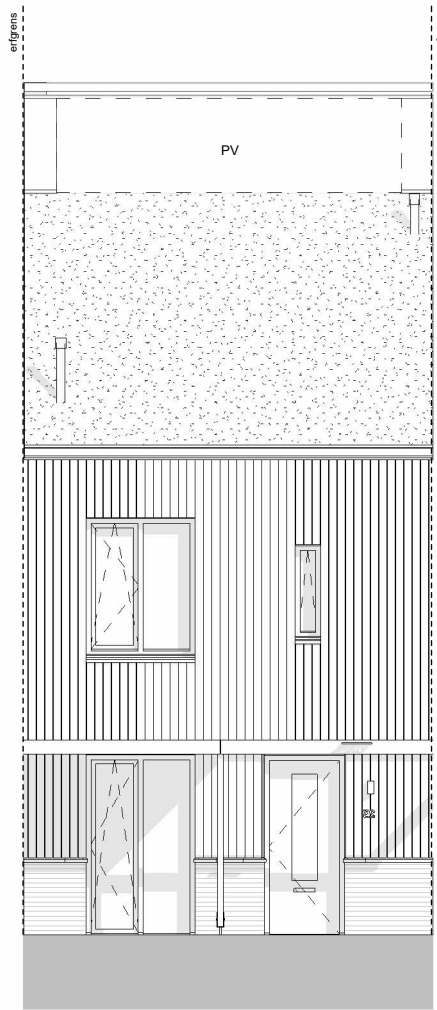

voorgevel

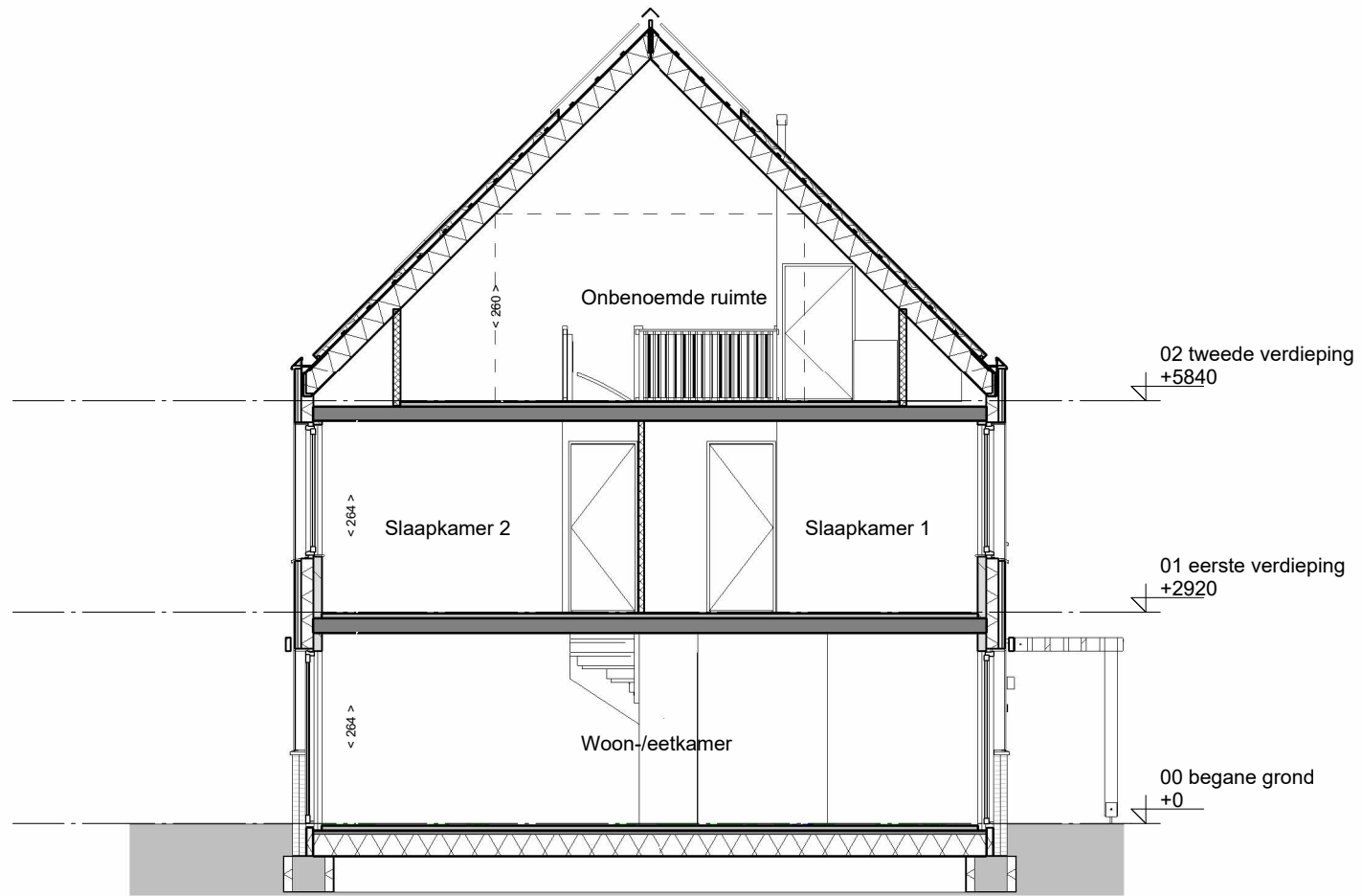

doorsnede

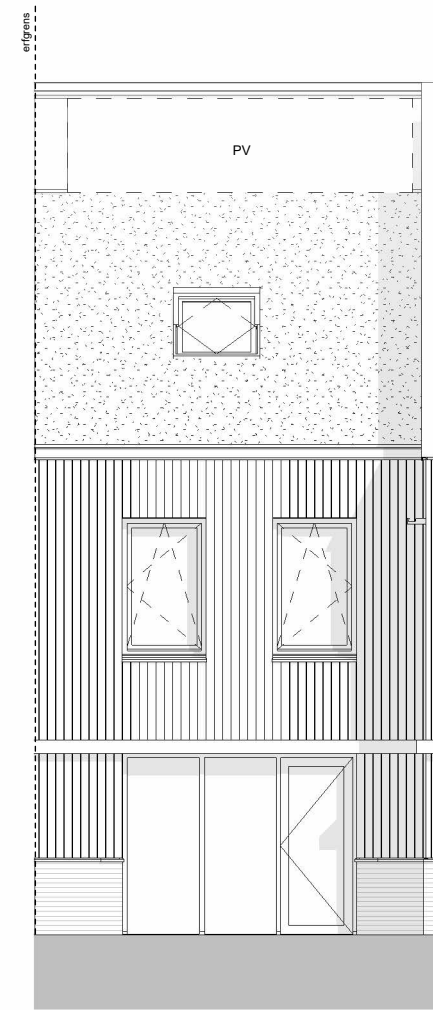

achtergevel

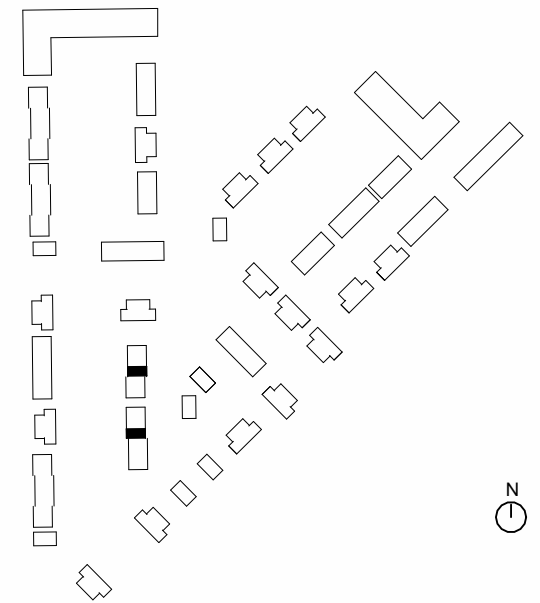

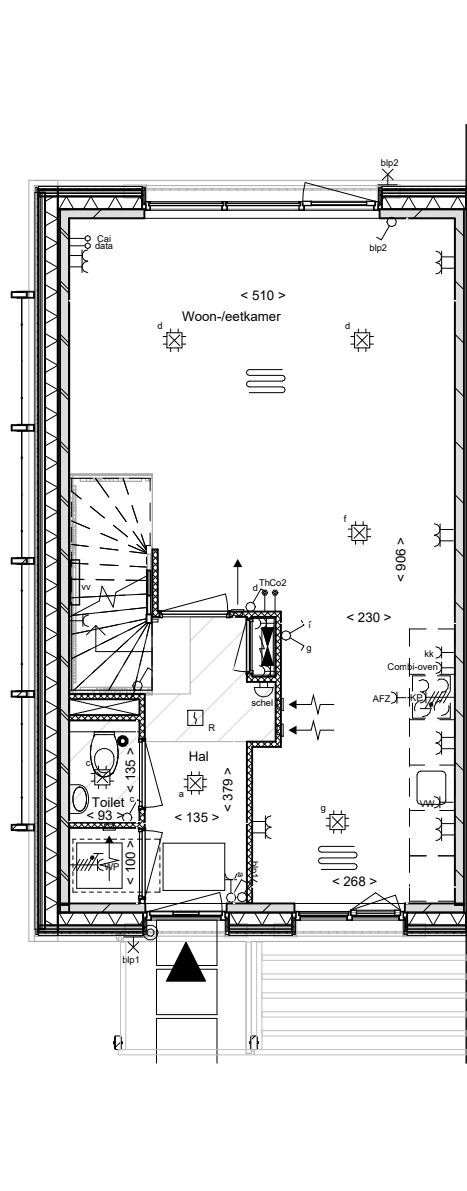

begane grond

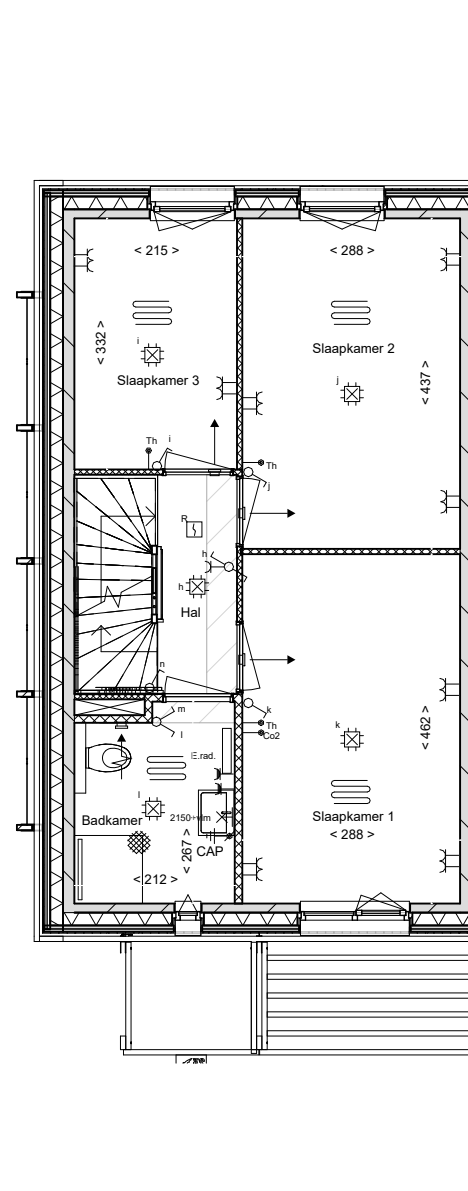

eerste verdieping

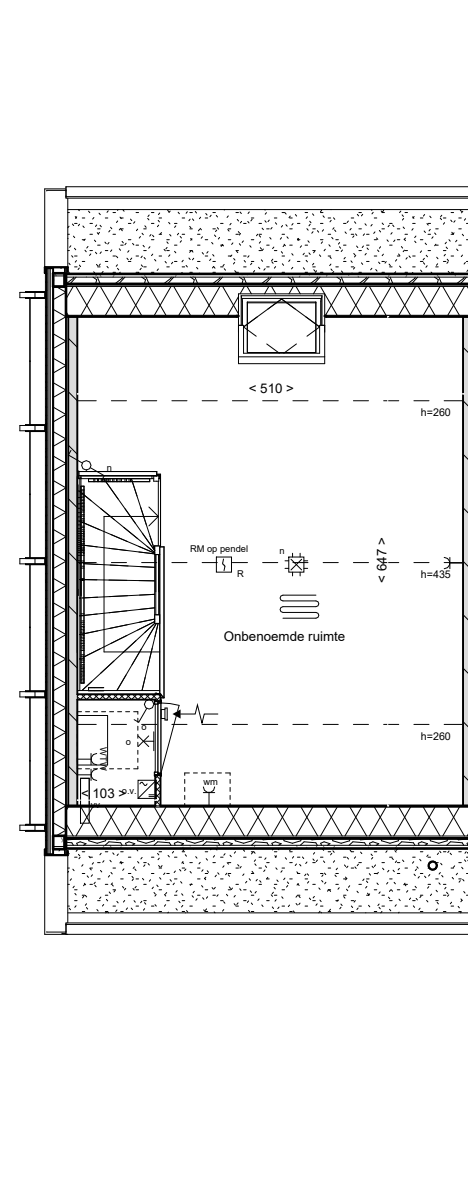

zolder

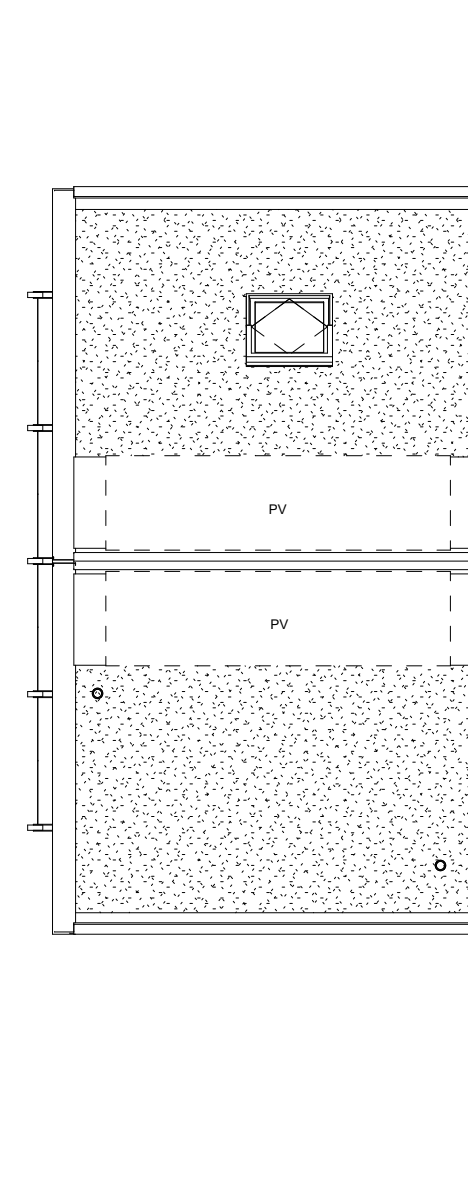

dakaanzicht

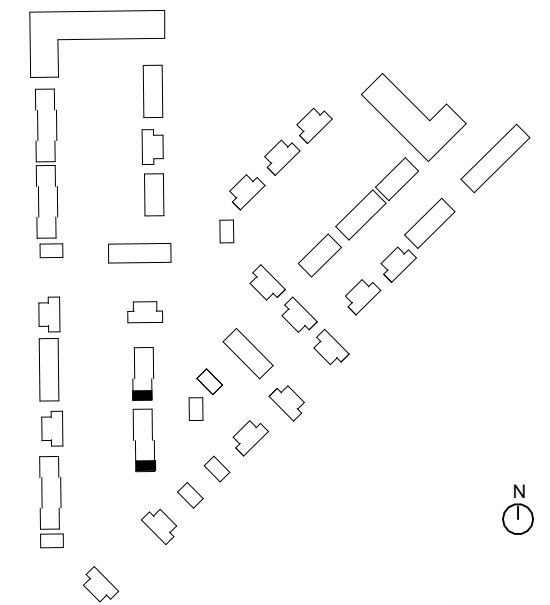

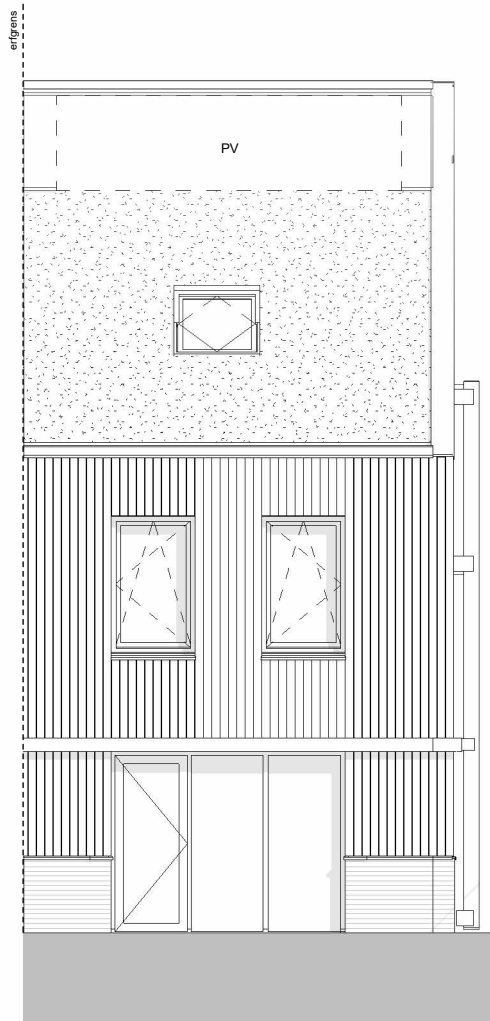

achtergevel

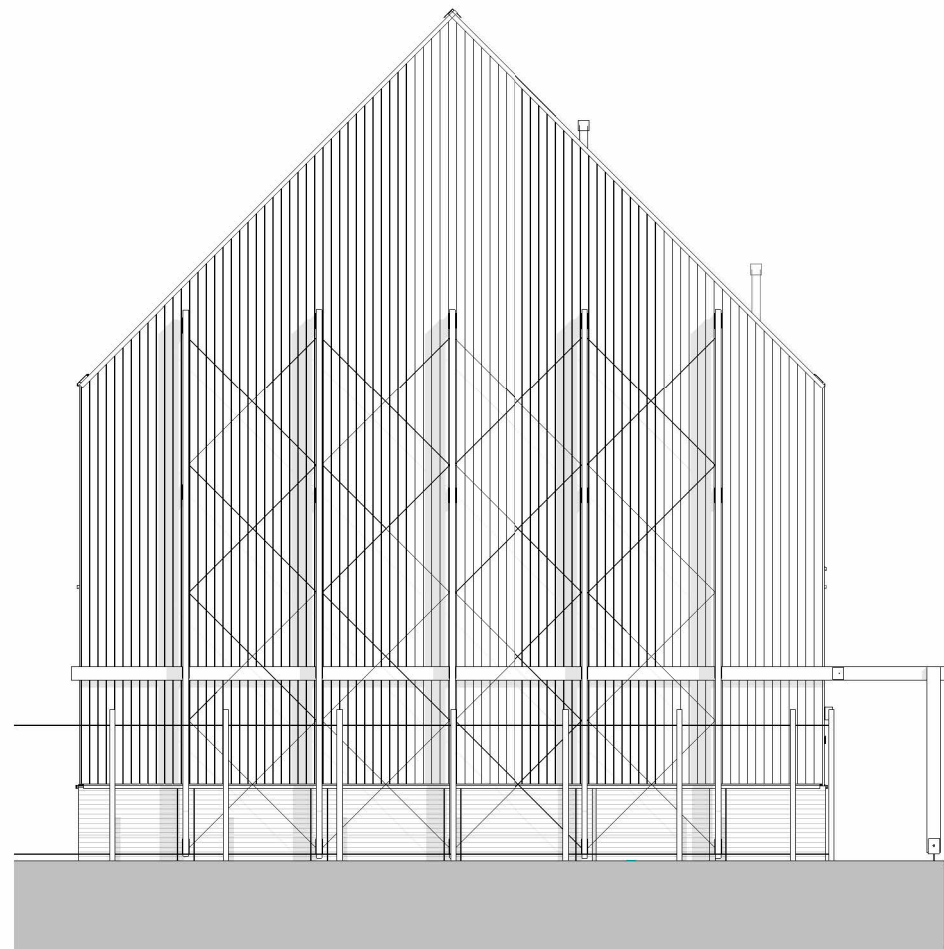

kopgevel met voorziening voor koele kop

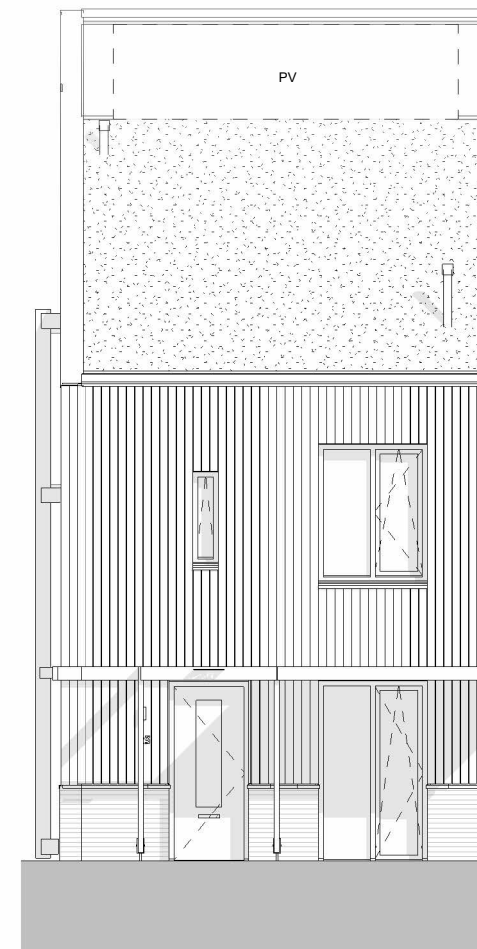

voorgevel

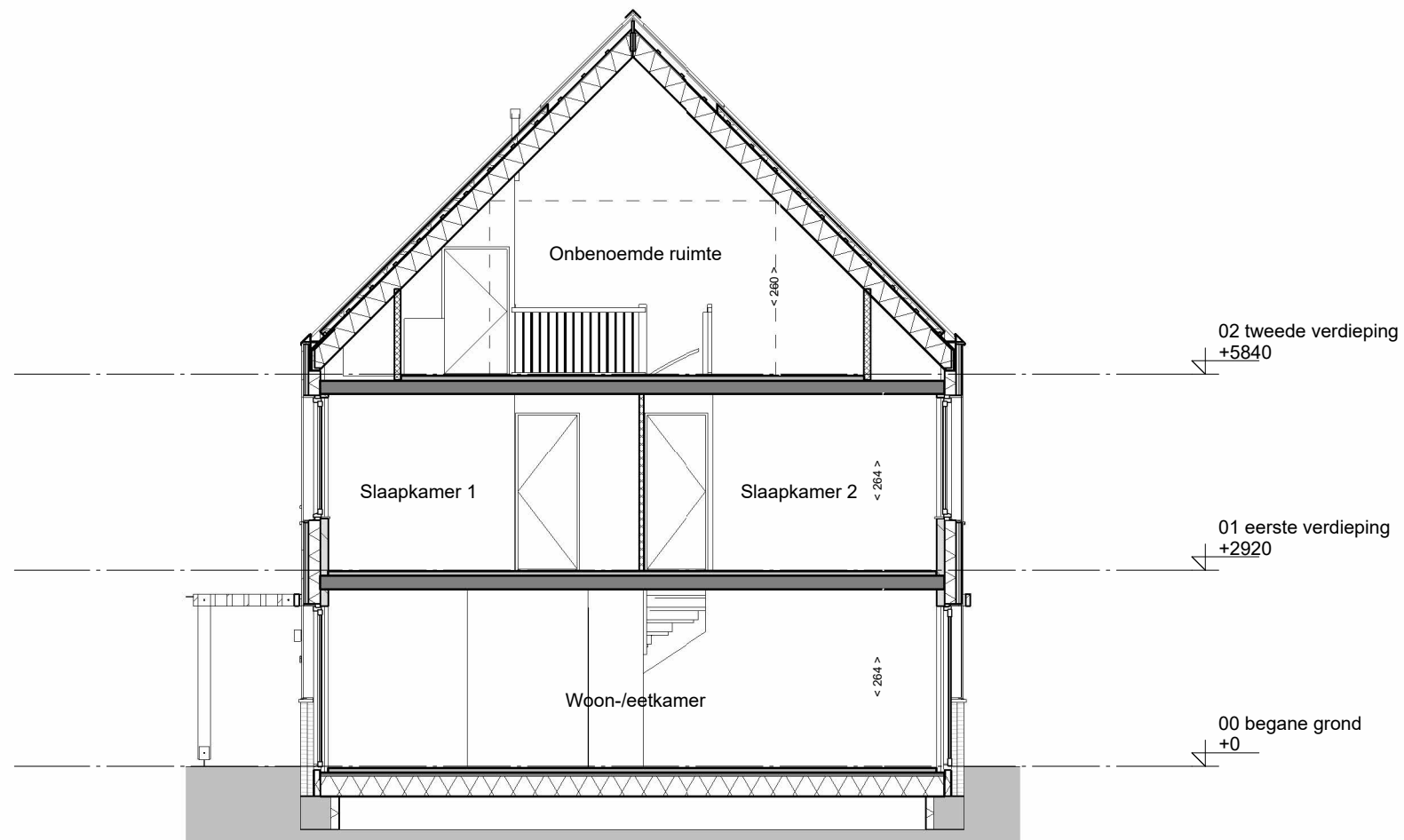

doorsnede

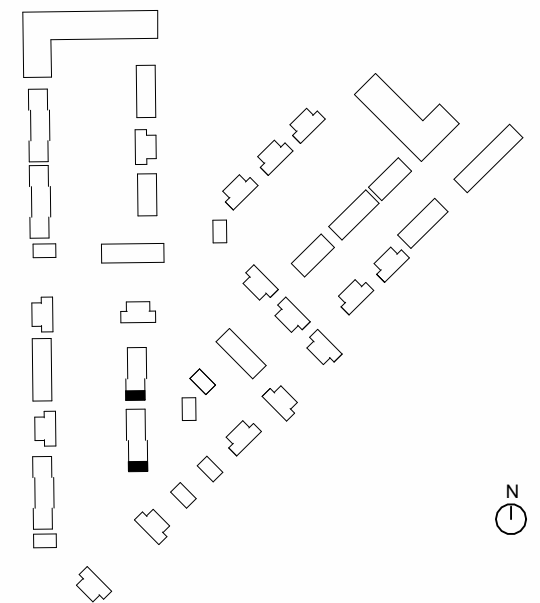

Omschrijving  
**Gevelaanzichten en doorsneden voorlopig**

Onderdeel Verkooptekening	tekeningnummer <b>VK-074-2</b>	getekend	schaal	formaat
Bouwnummer(s) 74 & 80	-	-	1 : 100	A3

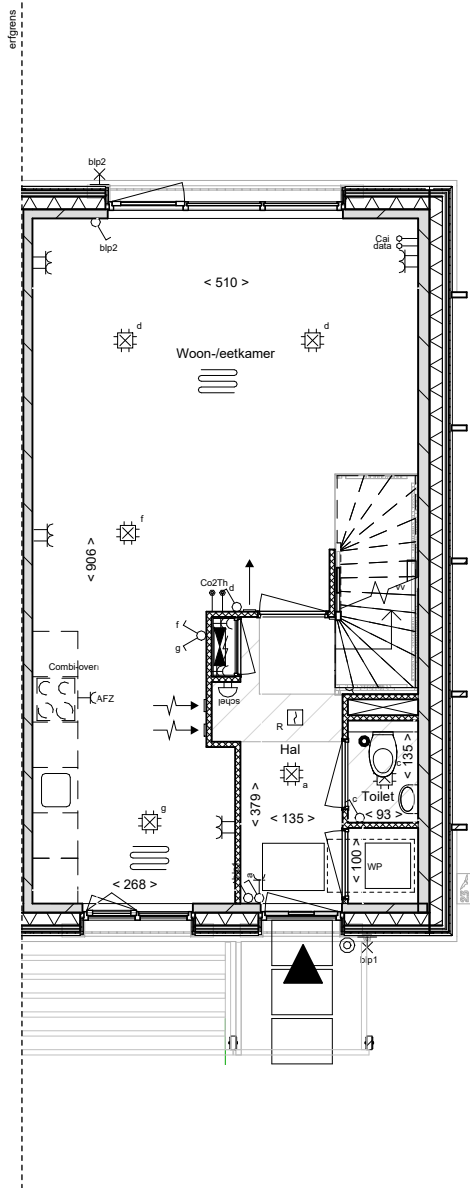

begane grond

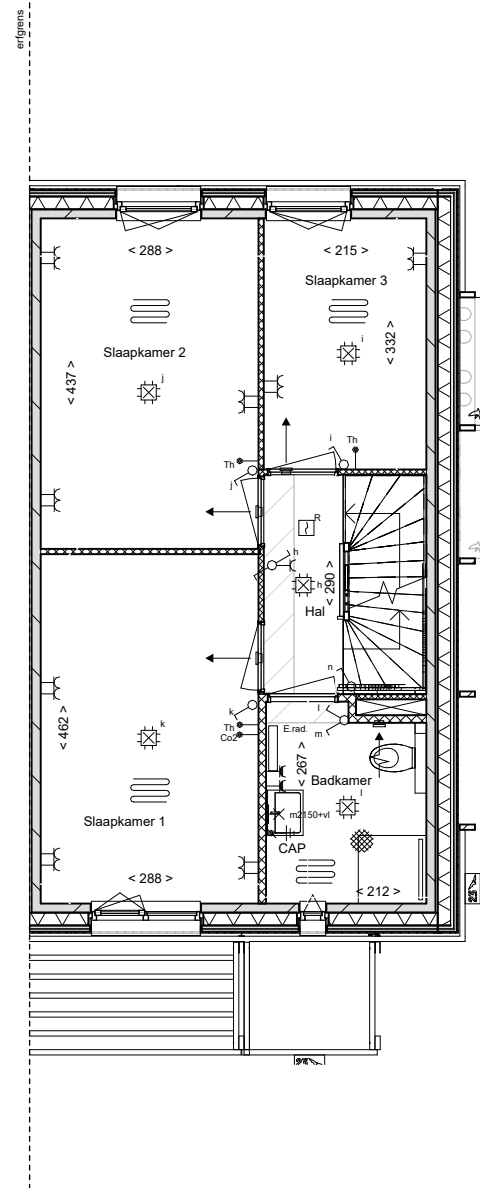

eerste verdieping

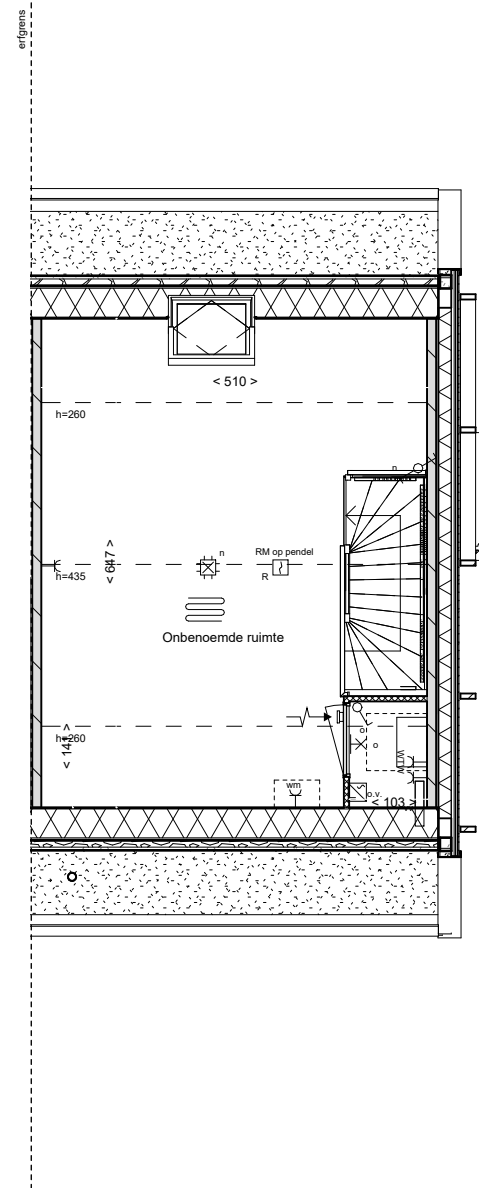

zolder

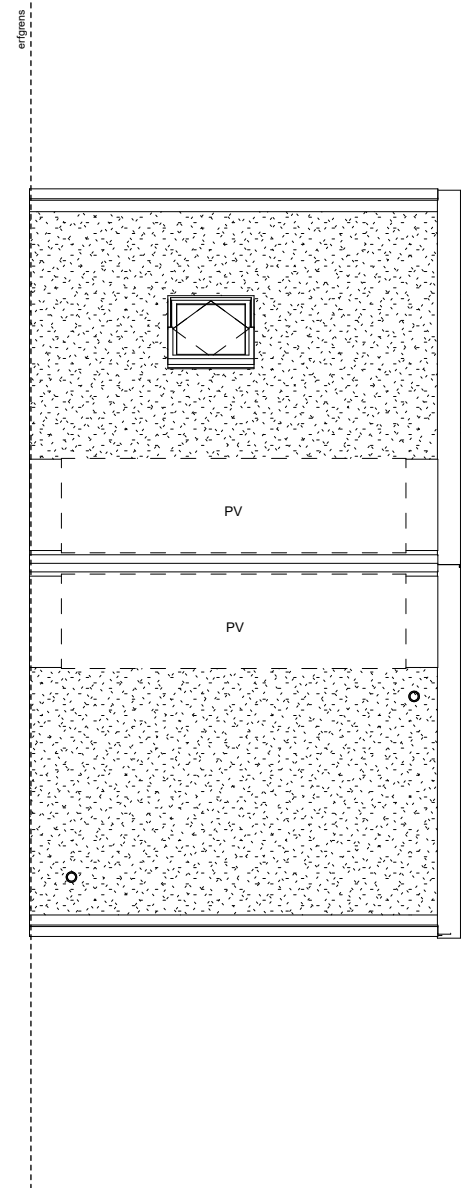

dakaanzicht

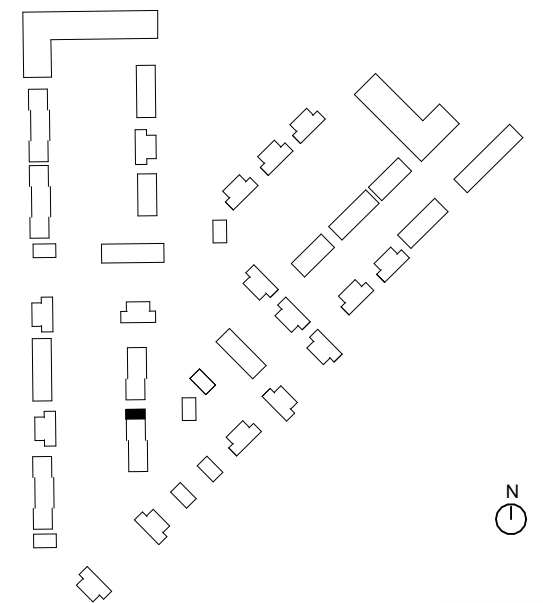

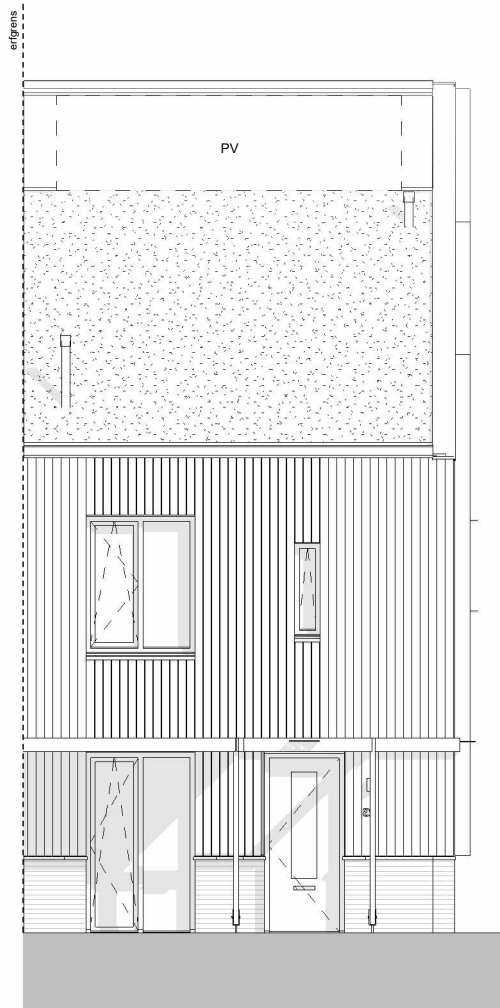

voorgevel

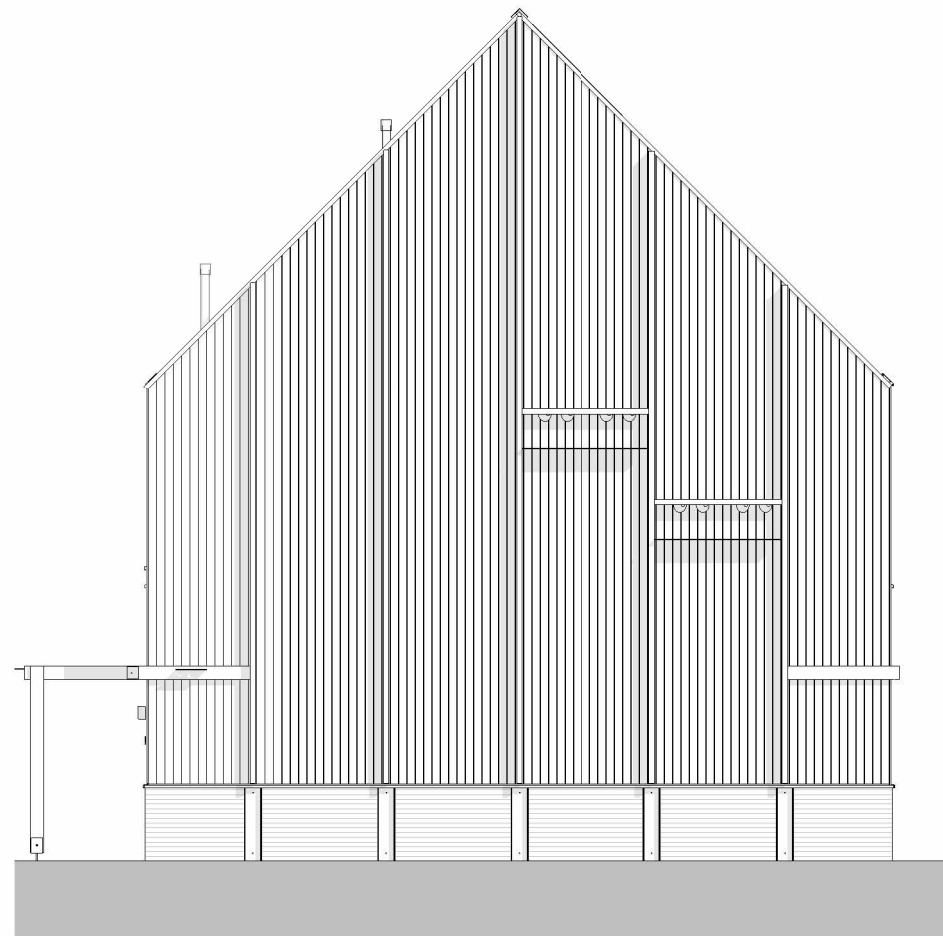

kopgevel met zwaluwnesten

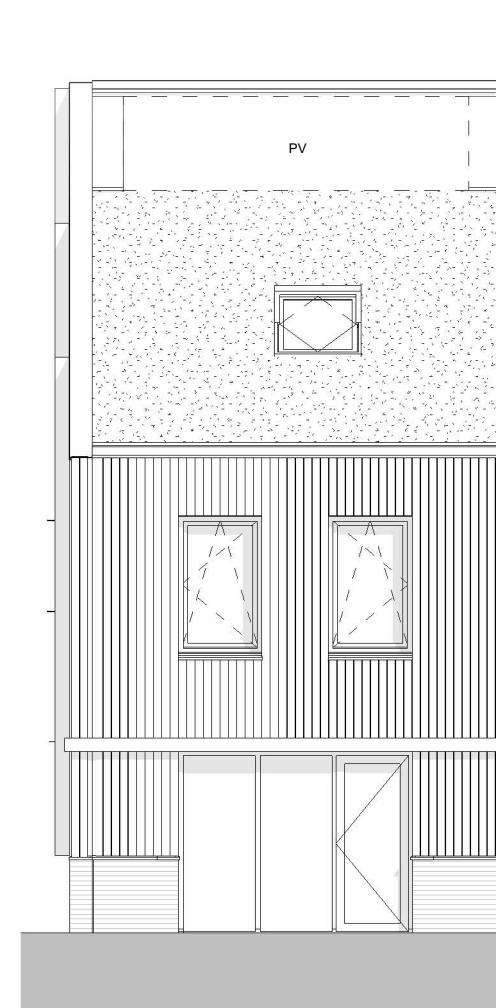

achtergevel

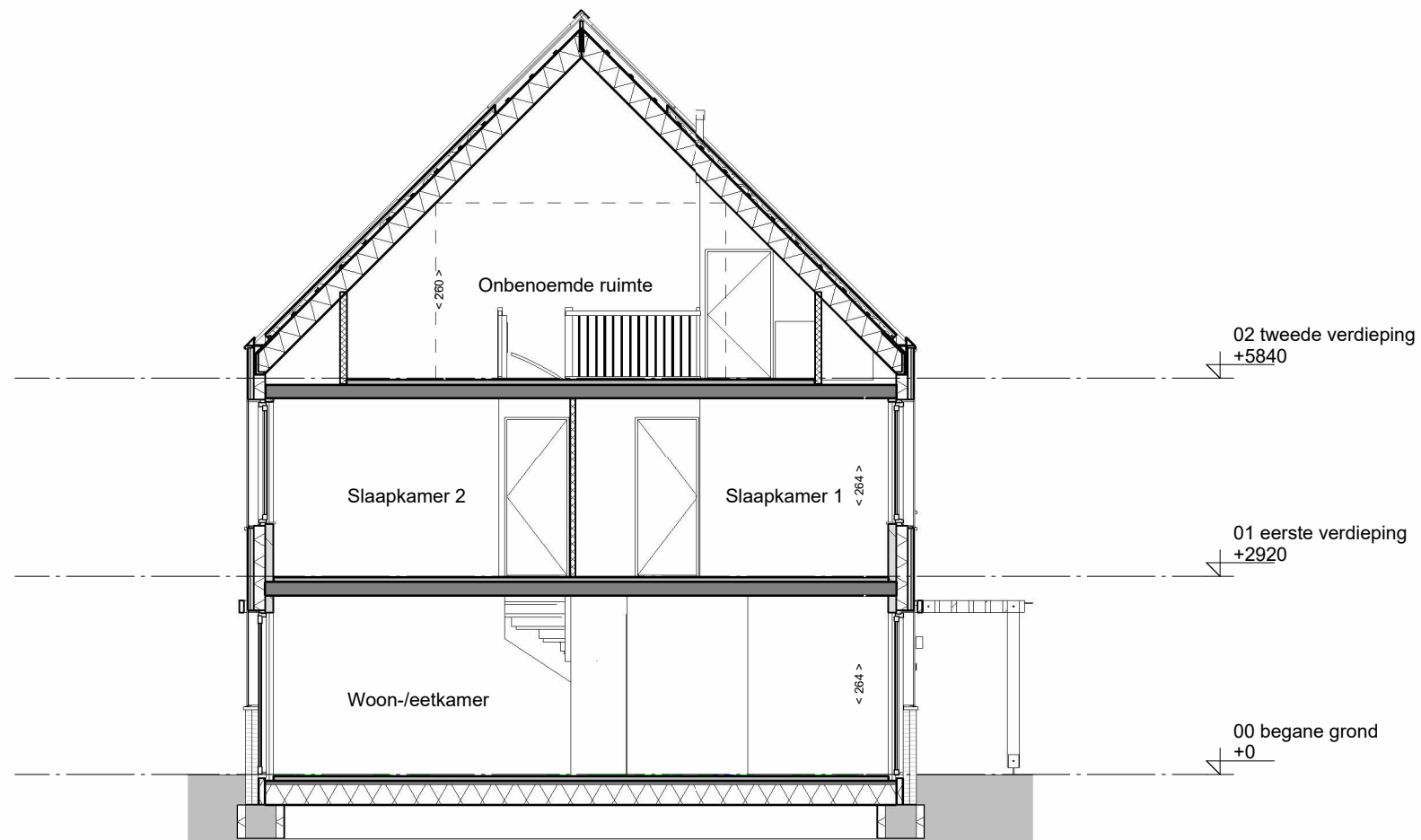

doorsnede

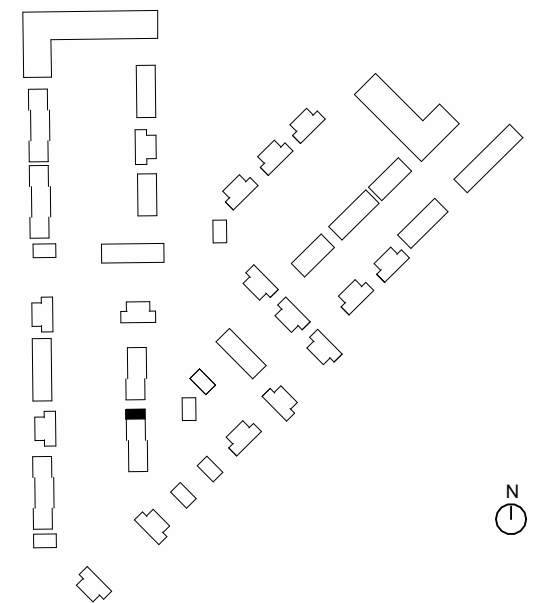











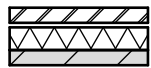

Omschrijving  
**Gevelaanzichten en doorsneden voorlopig**

Onderdeel Verkooptekening	tekeningnummer <b>VK-075-2</b>	schaal	formaat
Bouwnummer(s) 75	getekend -	1 : 100	A3

# LEGENDA

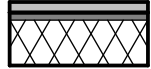
## Bouwkundig, plattegrond en doorsnede

	Kalkzandsteen		groendak
	geïsoleerde gevel met metselwerk buitenspouwblad		kruipluik, positie indicatief
	geïsoleerde gevel met hout of bamboe buitenspouwblad		hemelwaterafvoer (hwa)
	lichte scheidingswand Gibo / Gibo zwaar / Hydro / kalkzandsteen		dakdoorvoer
	geïsoleerde dakelementen		verlaagd plafond
	geïsoleerde ribcassettenvloer v.v. dekvloer		
	breedplaatvloer v.v. dekvloer		

## Bouwkundig, aanzicht

	metselwerk		gierzwaluw nestkast		insectenhotel
	houten of bamboe gevelbekleding		huiszwaluw nestkast		aanhaakvoorziening ladder t.b.v. onderhoud dak. Één per rij per dakoriëntatie
			vleermuis nestkast		
			verlichtingsarmatuur bij voordeur boven huisnummer		

## Draairichting ramen en deuren

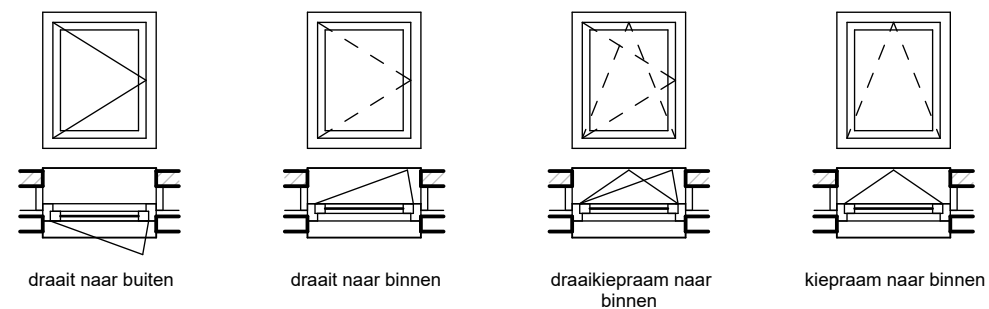

## Maatvoering



- < 100 > afstand van wand tot wand, gemeten in centimeters, gemeten zonder aftrek van dikte tegelwerk
- < 100 >\* afstand van muur tot hellend dak op een hoogte van 1500mm boven vloerniveau, gemeten in centimeters

- Kleine wijzigingen voorbehouden
- Aan de maatvoering kunnen geen rechten worden ontleend
- Maatvoering betreft circa-maten en is aangegeven in centimeters
- Maatvoering bij schuine daken is tot de 150cm hoogtelijn
- Elektrapunten, contour keukenopstelling, ventilatiepunten, vloerverwarmingsverdelers, hemelwaterafvoeren, radiator en rookmelders zijn indicatief aangegeven
- Het is mogelijk dat niet alle symbolen uit de legenda van toepassing zijn op uw woningtype

# LEGENDA INSTALLATIES

## Symbolen verklaring

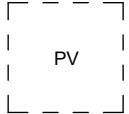
	Aansluitpunt licht		Wandcontactdoos 3 fasen, nul en beschermingscontact
	Aansluitpunt licht, wand		Omvormer
	Centraaldoos met lichtpunt		Centraal aardpunt
	Armatuur aan de wand		Aardmat
	Rookmelder		Luchtinblaasventiel
	Aansluitpunt niet bedraad		Luchtafzuigventiel
	Aansluitpunt bedraad		Luchtinblaas wandventiel
	Verdeelinrichting meterkast groepenkast		Luchtafzuig wandventiel
	Beldrukker		Vloerverwarming
	Schel		Verdeler vloerverwarming
	Schakelaar 1-polig		Elektrische radiator
	Schakelaar wissel		wtw Warmte terugwin-unit
	Schakelaar serie		wp Warmtepomp
	Wandcontactdoos 1-voudig met beschermingscontact		wm-wd Wasmachine/wasdroger
	Wandcontactdoos 2-voudig met beschermingscontact		th Thermostaat
			CO2 Co2 meter
			Buiten kraantje

	zone PV-panelen
	schacht

## Opmerkingen

Aansluitpunten keuken ter indicatie, definitieve positie conform keukenleverancier.